

Board of Directors San Simeon Community Services District



REGULAR BOARD MEETING PACKET

**Thursday, June 10, 2021
Meeting Start Time 5:00 pm**

**Virtual Board Meeting via Zoom
Meeting Room: 927-053-7206
Password: 114376**

Prepared by:



GRACE
ENVIRONMENTAL SERVICES

Board Meeting Brown Act Check Sheet

Does the agenda have the correct:

Meeting location

Meeting time

Is the agenda posted 72 hours prior to the Regular meeting

Posting 1 District Office

Posting 2 Post Office

Posting 3 Chamber of Commerce

Is the agenda on the website 72 hours prior to the Regular meeting

Has the Board Packet been distributed to the Board

At the time of Packet Distribution to the Board has the Packet Been:

Distributed to the individuals / entities on the Distribution List

Loaded on the Website

Budget Committee Meeting

Does the agenda have the correct:

Meeting location

Meeting time

Is the agenda posted 72 hours prior to the Regular meeting

Posting 1 District Office

Posting 2 Corner Store

Posting 3 Chamber of Commerce

Water Committee Meeting

Does the agenda have the correct:

Meeting location

Meeting time

Is the agenda posted 72 hours prior to the Regular meeting

Posting 1 District Office

Posting 2 Corner Store

Posting 3 Chamber of Commerce

AGENDA
SAN SIMEON COMMUNITY SERVICES DISTRICT
BOARD OF DIRECTORS REGULAR MEETING
Thursday, June 10, 2021
5:00 pm

Pursuant to Governor Gavin Newsom's Executive Order N-29-20 dated March 17, 2020 and the San Luis Obispo County Local Emergency Order and Regulation regarding COVID-19 dated March 18, 2020, this meeting shall occur as a virtual teleconference using the Zoom app. Members of the public cannot physically attend this meeting.

Internet Meeting Location

Join Zoom Meeting

<https://us02web.zoom.us/j/9270537206?pwd=RDNNcTErb2E1TmswRG51WGNEZVJLQT09>

Meeting ID: 927 053 7206

Password: 114376

One tap mobile

+1 669 900 9128, 9270537206# US (San Jose)

+1 346 248 7799, 9270537206# US (Houston)

The following commands can be entered via DTMF tones using your **phone's dial pad while in a Zoom meeting**: *6 - Toggle mute/unmute. *9 - **Raise hand**.

Time: June 10, 2021 5:00 PM Pacific Time

NOTE: On the day of the meeting, the virtual meeting room will be open beginning at 4:30 PM. If you are unable to access the meeting please contact Cortney Murguia at (805) 927-4778 prior to the 5:00 PM meeting start time and staff can assist you in accessing the meeting. Should you have any questions related to the information on this agenda or if you wish to submit public comment in the written format you can email Cortney Murguia at admin@sansimeoncsd.org. Members of the public can also contact the District office at (805) 927-4778 or (805) 400-7399 with any questions or concerns related to this agenda or accessing the meeting.

1. REGULAR SESSION: 5:00 PM

A. Roll Call

2. CLOSED SESSION –

A. Public Comment

B. Pursuant to Government Code Section 54956.9 (d)(2) Conference with District Legal Counsel regarding anticipated litigation. Number of cases: one (1) Robert Hather.

3. HEARING ITEM:

A. Public hearing regarding Robert Hather request for hardship exemption under Ordinance 102.

4. PUBLIC COMMENT FOR ITEMS NOT ON THE AGENDA:

Public Comment - Any member of the public may address the Board relating to any matter within the Board's jurisdiction, provided the matter is not on the Board's agenda. Presentations are limited to

three (3) minutes or less with additional time at the discretion of the Chair. Your comments should be directed to the Board as a whole and not directed to individual Board members. The Brown Act restricts the Board from taking formal action on matters not published on the agenda.

5. SPECIAL PRESENTATIONS AND REPORTS:

A. STAFF REPORTS:

- i. **Sheriff's Report** – Report for May.
- ii. **Superintendent's Report** – Summary of May activities.
- iii. **General Manager's Report** – Summary of May Activities.
- iv. **District Financial Summary** – Summary of May Financials.
- v. **District Counsel's Report** – Summary of May Activities.

B. AD-HOC COMMITTEE REPORTS:

- i. **Status Report** – Disbursements Journal Review Committee.
- ii. **Status Report** – Policy & Procedures Committee.
- iii. **Status Report** – Update on District Ordinance 107 Parking on District Streets and draft Ordinance 122 Parking on District Streets.
- iv. **Status Report** – Budget Committee.
- v. **Status Report** – Water Committee.

C. PUBLIC COMMENTS ON SPECIAL PRESENTATIONS AND REPORTS:

Public Comment - This public comment period provides an opportunity for members of the public to address the Board on matters discussed during Agenda Item #5 – Special Presentations and Reports. If a member of the public wishes to speak at this time, Public Comment is limited to three (3) minutes.

6. CONSENT AGENDA ITEMS:

A. Review and approval of Minutes for the Regular Meeting on May 13, 2021.

B. Review and approval of Minutes for the Special Meeting on May 27, 2021.

C. Review and approval of Disbursements Journal.

D. PUBLIC COMMENT ON CONSENT AGENDA ITEMS:

Public Comment - This public comment period provides an opportunity for members of the public to address the Board on matters discussed during Agenda Item #6 –Consent Agenda Items. If a member of the public wishes to speak at this time, Public Comment is limited to three (3) minutes.

7. BUSINESS ACTION ITEMS:

Public Comment – Public comment will be allowed for each individual business item. Members of the public wishing to speak on business items may do so when recognized by the Presiding Officer. If a member of the public wishes to speak at this time, Public Comment is limited to three (3) minutes per person for each business item.

A. Discussion regarding the FY 2021/2022 Budget.

B. Direction to staff regarding entering into an agreement with Raider Painting to recoat the pipe bridge not to exceed the amount of \$45,000.00.

- C. **Direction to staff regarding entering into an agreement with RNM Engineering, Inc. for construction services management not to exceed the amount of \$9000.00.**
- D. **Discussion regarding the Districts existing liability insurance policy with Special District Risk Management Authority (SDRMA) renewal invoice due July 15, 2021.**
- E. **Discussion regarding the District hiring a public relations consultant.**
- F. **Direction to staff regarding the contract with the State of California regarding State Parks' wastewater treatment.**
- G. **Discussion regarding public comment and Regular Meeting Agenda layout.**

8. BOARD/STAFF GENERAL DISCUSSIONS AND PROPOSED AGENDA ITEMS – Requests from Board members to Staff to receive feedback, prepare information, and/or place an item on a future agenda(s).

9. ADJOURNMENT

All staff reports or other written documentation, including any supplemental material distributed to a majority of the Board within 72 hours of a regular meeting, relating to each item of business on the agenda are available for public inspection during regular business hours in the District office, 111 Pico Avenue, San Simeon. If requested, this agenda shall be made available in appropriate alternative formats to persons with a disability, as required by the Americans with Disabilities Act. To make a request for a disability-related modification or accommodation, contact the District Administrator at 805-927-4778 as soon as possible and at least 48 hours prior to the meeting date. This agenda was prepared and posted pursuant to Government Code Section 54954.2.

PAGE INTENTIONALLY LEFT BLANK

3. HEARING ITEM:

- A. Public hearing regarding Robert Hather request for hardship exemption under Ordinance 102.**

Stulberg Correspondence November 24, 2020

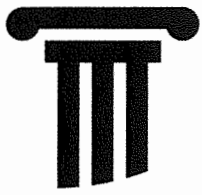

Jeffrey D. Stulberg
A LAW CORPORATION

November 24, 2020

Via Email & Regular Mail

Board of Directors
San Simeon Community Services District
c/o Jeffrey A. Minnery, Esq.
Adamski, Moroski, Madden,
Cumberland & Green LLP
P.O. Box 3835
San Luis Obispo, CA 93403-3855

Re: Robert Hather's Hardship Application for a Will-Serve Letter

Dear Sirs and Madams:

The San Simeon Community Services District's long-standing water moratorium has created an unjust financial burden on local property-owner Robert Hather. It is within the powers of the Board of Directors to grant Mr. Hather immediate relief from this hardship. The overdue repeal of the water moratorium may or may not require a lengthy environmental review process, but Mr. Hather has waited patiently for nearly seventeen years and now, at 67-years, he simply cannot afford to wait any longer. Mr. Hather has plans to develop his vacant property on Avonne Avenue—once a Will-Serve Letter has been issued—completion of that townhouse project which includes affordable housing units that would allow him to finally retire while simultaneously providing the north coast with desperately needed housing.

Furthermore, the lack of water treatment and storage infrastructure that caused the original water moratorium in 1986 has since been remedied. The water emergency no longer exists. Therefore, in light of the unfair financial losses sustained by Mr. Hather under Ordinance No. 102 as well as his distinct investment-backed expectations in the otherwise valueless vacant property, there is ample justification to issue him a Will-Serve Letter prior to repealing the moratorium. Alternatively, there is evidence in the record that the application of certain provisions of Ordinance No. 102 to Mr. Hather's property is affecting an unconstitutional taking and any such provisions should be disregarded.

Because (1) sufficient water supply now exists, (2) granting a single Hardship Application will have a minuscule or no environmental impact, and (3) any resulting project will be subject to environmental review throughout the subsequent permitting process, this limited action qualifies for exemption from the California Environmental Quality Act under the "Common Sense" exemption.

FACTUAL BACKGROUND

The Parties

Robert Hather is a 67-year-old resident of San Luis Obispo County. Mr. Hather is no stranger to water issues. His former company, Lifewater Drilling Technology, designs and distributes water well drilling

systems “especially equipped to overcome the challenges found in developing countries.”¹ Their LDT 360 Cable Tool Drill Rig was recognized at the March 2014 World Water Day event in Washington, D.C.²

Mr. Hather is a dedicated Rotarian and active member of the community. He hopes to retire soon but is currently unable to stop working as a money manager because a goodly portion of his retirement planning has been tied to the property which is the subject of this Hardship Application for nearly seventeen years.

The San Simeon Community Services District (“CSD”) was formed by election under California’s Community Services District Law (Gov Code § 61000 et seq) in May 1961 to provide a variety of services to residents of the San Simeon area, including water and sewage. In 1966 the CSD acquired the water and sewage infrastructure of Rancho San Simeon Acres Service Corporation. The CSD currently serves about 208 water and sewage connections for residential and commercial users.³

An elected five-person Board of Directors (“Board”) governs the CSD and is its main decision-making body. The Board’s purview includes the consideration of Hardship Applications for relief from the CSD’s long-standing moratorium on new water connections.

Description of the Property

The property that is the subject of this Hardship Application is identified as San Luis Obispo County Assessor’s Parcel Number 013-071-009. The legal description is attached as Exhibit A. It is a vacant lot comprising 1.1 acres of the Arbuckle Tract in Rancho San Simeon along the northeast side of Avonne Avenue. It is bordered on the southeast by an apartment complex and on the northwest by single and multi-family residences. The lot directly across Avonne Avenue is also vacant. Beyond that, along Cabrillo Highway, is Motel 6, interposed between the property and the view from the ocean.

The property is zoned Residential Multi-Family. A map of San Simeon showing existing developments and zoning overlays is attached as Exhibit B. The property falls within the California Coastal Zone. The lot currently sits empty, devoid even of trees; its only vegetation is seasonal grass which Mr. Hather is required to keep mowed no higher than six inches.

San Simeon Water Moratorium

On January 15, 1986, the CSD Board passed Ordinance No. 61 “Establishing a Temporary Moratorium on the Issuance of Water and Sewer Connections Within the Boundaries of the District.” They found that “[t]he granting of additional water and sewer connections within the District would result in an immediate threat to the public health and safety” due to “a serious water quality problem” in the district. By its own terms, Ordinance No. 61 would be automatically repealed on August 15, 1986 unless extended or replaced. On August 13, 1986, Ordinance No. 62 extended the temporary moratorium for another eight months, until April 1, 1987.

On April 1, 1987, the CSD Board passed Ordinance No. 63, extending the moratorium for a full year. Finally, on March 9, 1988, Ordinance No. 66 extended the moratorium indefinitely, leaving its provisions

¹ <https://www.lifewaterdrillingtechnology.com/about-us.html>

² <https://www.lifewaterdrillingtechnology.com/april-9-2014---world-water-day.html>

³ Tanner, Kathe; [San Simeon CSD has banned new water hookups for 31 years. This study could change that](#); The Tribune, December 3, 2019.

“in effect until repealed.” The new ordinance stated that “[t]he District is diligently pursuing long term supplemental water supplies, but until the time when such supply is available, it is necessary to continue the existing moratorium.” Ordinance No. 65, adopted February 10, 1988, established a waiting list for water service: “any property owner may deposit the then current connection fees and be placed on the District’s waiting list for service.” This waiting list is currently published and has been the subject of additional ordinances, including Ordinance No. 101, which identifies “Waiting List Commitments” as a category of existing commitments for water service.

On October 11, 2006, the CSD Board passed Ordinance No. 102, which remains in effect “until repealed.” In addition to carrying forward the terms of its predecessors, Ordinance No. 102 introduced a Hardship Application, permitting “any person aggrieved by this moratorium law” to petition the Board for a public hearing on the merits of their claim for an exemption. Ordinance No. 102 also gives the Board the ability to disregard any provision that may lead to an unconstitutional taking of property. It claims exemption from the California Environmental Quality Act (“CEQA”) under Water Code section 10652 and CEQA Guidelines 15269(c) and 15282(w).

Since 2006, significant infrastructure improvements have drastically reduced or eliminated the CSD’s water emergency. In 2012, the Water Re-Use Project was completed. A Reverse Osmosis Unit was installed in 2016 to “treat brackish and mineral heavy community water from the existing well field.”⁴ The CSD filed a mitigate negative declaration in September 2019 for the installation of two new water storage tanks which hold more than 800,000 gallons for fire suppression. The Notice of Completion is attached as Exhibit C.

At its regular meeting on November 13, 2019, the Board discussed lifting the water moratorium. They voted to direct staff to pursue proposals for an environmental review document after receiving information that repeal of the moratorium could be subject to the provisions of CEQA. A request for proposals was issued in February 2020, but only one response was received. The Board decided to seek a second round of proposals, but COVID-19 delayed the process.

The moratorium was again discussed at the regular meeting of the Board on September 9, 2020. The Board considered the implications of either lifting the moratorium or serving those on the waiting list without further environmental review. Board members were encouraged to do their own research and staff was directed to develop a process to move forward with the repeal of Ordinance No. 102.

At the October 14, 2020 CSD Board meeting, an ad hoc committee was established to review the process of Will-Serve letters. On October 28, 2020, the Board discussed policies and procedures for reviewing proposals from environmental consultants to conduct the environmental analysis regarding repeal of the water moratorium. In November 2020, the Board hired consultant Paavo Ogren, recently retired from the Oceano Community Services District, to help guide the process of lifting the moratorium.

Property Narrative

Applicant Robert Hather purchased the property in July 2004 as a retirement investment. He relied in part on the water that would be freed by the Hearst Ranch conservation easement, but instead of loosening restrictions on new connections, Ordinance No. 102 was passed in 2006, extending the moratorium on water and sewer service on August 27, 2014. In 2008 or 2009, Mr. Hather agreed to sell the property for

⁴ <https://sansimeoncsd.org/facilities/>

\$50,000, an astonishing loss of nearly 75% of its value less than half a decade prior. But escrow fell through and he has since been unable to resell the property while water service remains unavailable.⁵

In September 2019 Mr. Hather paid for a pre-application planning meeting with the County of San Luis Obispo Department of Planning and Building. The letter summarizing this meeting is attached as Exhibit D. They discussed plans for a 15-unit residential housing development proposal, attached as Exhibit E. According to the County of San Luis Obispo, a Will-Serve Letter for water and sewer is required before applying for any of the associated permits.

Mr. Hather wrote to the CSD on October 30, 2019 to seek relief from the water moratorium. The Board considered his request at the November 13, 2019 meeting but decided that environmental review was required before repealing Ordinance No. 102. Mr., Hather renewed his efforts at the September 9, 2020 meeting, submitting a letter from attorney William Walter. He also participated in the October and November 2020 CSD meetings to continue advocating for the repeal of the water moratorium as well as the issuance of a Will-Serve letter for his property.

The property was recently reassessed for tax purposes and valued at \$86,593. However, the practical value of the property is currently a net-loss; Mr. Hather has no viable economic use for the property without water service but is still paying the property taxes and various maintenance charges. Once a Will-Serve Letter is issued, Mr. Hather has a good faith offer to develop the property in concert with a builder who intends to carry out the residential development plans.

HARDSHIP APPLICATION

Section V of Ordinance No. 102 states that “any person aggrieved” by the water moratorium may seek redress in the form of a Hardship Application which shall be considered by the CSD Board at a public hearing. A variety of factors may be considered by the board, including, but not limited to, the “nature and extent of financial hardship,” the extent of the proposed water usage, and the actual environmental impacts, if any that the project may have.

The Board’s decision to grant a Will-Serve Letter should, in the spirit of substantial justice, balance the general intent and purpose of the water moratorium with the actual effect on the individual property owner. In addition, the Board may impose reasonable stipulations and conditions on the grant of the Will-Serve Letter to ensure that the public purpose of the moratorium is fulfilled.

The equities in this case are firmly on the side of granting Mr. Hather’s Hardship Application. The financial hardship imposed by the moratorium is considerable, no potentially significant environmental impacts were identified during the pre-application planning process, and the project will provide much-needed housing to the region. Because the water emergency has been alleviated by new infrastructure, there is no longer a legitimate public interest in denying the Will-Serve Letter.

The Financial Hardship Is Preventing Mr. Hather from Retiring

Applicant Robert Hather invested a substantial part of his retirement savings into this property. Additionally, since purchasing the property in 2004, he has paid an estimated \$26,000 in property tax, \$2,400 in mowing services, \$3,940 to join the water and sewer waiting list, and \$3,094 in pre-application design and planning fees.

⁵ Note that Mr. Hather, a professional well-driller, explored the possibility of wells to supply the development, but the groundwater rights underlying his property were previously acquired by the CSD.

The Water Use Will Be Modest (Fifteen Residential Units)

The proposed development on the property (see Appendix E) comprises fifteen residential units, each with two-bedrooms and totaling approximately 1,100 square feet. Therefore, it will likely utilize fifteen “Equivalent Dwelling Units” as defined in CSD Ordinance No. 101. Under Article X, section Two of the California Constitution, “the water resources of the State [should] be put to beneficial use to the fullest extent of which they are capable.” Currently, housing is one of the most urgent needs on the Central Coast, making residential water service a highly beneficial use.

There Are No Known or Anticipated Environmental Problems

Mr. Hather, who has owned the property for nearly seventeen years, is unaware of any environmental problems associated with it. Furthermore, the pre-application planning meeting with the County of San Luis Obispo Department of Planning and Building identified no potential significant adverse environmental impacts related to the proposed development.

Because any development project on the property must be fully permitted by the County of San Luis Obispo before construction can begin, the CSD Board is assured that regardless of when the Will-Serve Letter is issued, all appropriate environmental review will be conducted prior to the actual connection of water and sewer services. It has not yet been determined whether any kind of environmental review will be necessary, however if it is, the initial study is unlikely to find significant environmental impacts.

Vegetation

The property is a vacant lot on which nothing grows but grasses, which are routinely mowed. There are no trees, shrubberies, or other vegetation present.

Traffic

According to San Luis Obispo County Department of Planning and Building, a Traffic Engineer Report will be required as part of the permit process for the project. Additionally, the project provides substantially more than the 27 required on-site parking spaces by incorporating a two-car garage into the ground floor of every dwelling unit.

Stormwater

The project proposal also requires a drainage plan as part of the permit process. There is a 20-foot set back surrounding the property, which is more than ample to accommodate depressions and gravel areas for drainage. Paved surfaces throughout the project will be permeable.

Existing Zoning is Appropriate for the Project Proposal

San Simeon currently has two zoning overlays: multi-family residential and commercial retail. The property where the project is being proposed is in the multi-family residential zone. The 1.1-acre property is zoned to support the fifteen residential units currently proposed.⁶

California’s housing crisis is ongoing. San Luis Obispo County completed its latest Regional Housing Needs Assessment (“RHNA”) in 2019.⁷ The total allocation for unincorporated areas of the county, including San Simeon, was 3,256 units; more than half of those need to be for very-low to moderate

⁶ The development plan for this property was originally more intensive, but zoning changes enacted while waiting for the water moratorium to be lifted required a reduction in the number of proposed units to the current fifteen.

⁷ San Luis Obispo County Regional Housing Needs Allocation 6th Housing Element Cycle: 2020 to 2028.

income households. Mr. Hather's development proposal will provide fifteen new homes, including two designated as affordable housing.

This Application Is in Harmony with the Purpose and Intent of Ordinance 102

The purpose of this Hardship Application is not to subvert the significant public interest regarding health and safety that underlies Ordinance No. 102. Its Section I: Findings state that "it is necessary to continue the existing water connection moratorium" until "long-term supplemental water supplies" are available. Given the considerable infrastructure improvements since Ordinance No. 102 was passed, the public policy justifications for the moratorium no longer exist.

Indeed, new and different threats have emerged to public health and safety, including an increasingly dire shortage of housing on the Central Coast. Mr. Hather's significant financial hardship as well as the public interest in promoting the development of new housing substantially outweigh any remaining public benefit to health and safety that Ordinance No. 102, now obsolete by its own terms, still offers.

Withholding the Will-Serve Letter Effects a Constitutional Taking of Mr. Hather's Property

Under Section VI of Ordinance No. 102, if the Board determines that the application of the Ordinance to a particular project raises the issue of a constitutional taking of private property, they "shall disregard such provision or provisions" of the Ordinance to "avoid such unconstitutional taking."

Constitutional takings are a complex and fact-intensive area of law. They deal with the principle that private property cannot be taken for public use without compensation. USCS Const. Amend. 5; Cal. Const. art. 1 § 19. A regulatory taking occurs when government action substantially diminishes the value of private property. Depending on the circumstances, the affected owner may be entitled to compensation for their loss even though they still retain title to the property.

When a government regulation eliminates nearly all (95% or more) economic value in the property the taking is "categorical" and the owner is entitled to compensation. *See Lucas v. S.C. Coastal Council* (1992) 505 U.S. 1003 (landowner barred from any development of her coastal lots in a developed subdivision entitled to compensation).

In *Lucas*, the plaintiff property owner was prevented from building on her beachfront land by a law designed to protect public resources. Despite the public interest underlying the regulation, the fact that there was no economically viable use for her property led the Supreme Court of the United States to hold that a constitutional taking had occurred and she was entitled to compensation. Mr. Hather is similarly situated regarding his vacant lot on Avonne Avenue; he is indefinitely enjoined from any economically viable use of his land while the moratorium remains in effect.

The *Lucas* standard of no economically viable use is admittedly hard to prove. In *Tahoe-Sierra Pres. Council v. Tahoe Reg'l Planning Agency* (2002) 535 U.S. 302, a temporary moratorium on development was not a categorical taking. However, Mr. Hather's case is distinguished from *Tahoe-Sierra* because the moratoria there were limited, one for 24 months and the other for about 8 months; the San Simeon Water Moratorium has been in place for 34 years with no end yet in sight.

Alternatively, if Mr. Hather has not been deprived of all economically viable use of his property, he may still be entitled to compensation under the landmark three-part test announced in *New York v. Penn Cent. Transp. Co.* (1972) 406 U.S. 944. When a government regulation diminishes the value of private property, courts look at (1) the economic impact on the claimant, (2) the extent of the interference with distinct investment-backed expectations, and (3) the nature of the governmental action. In particular, when a

regulation that is in the general public interest results in an unfair share of the cost being born by a few individual property owners, a taking is more likely to be found.

Mr. Hather and the other handful of property owners on the waiting list for water and sewer connections have long-standing investment backed expectations. Whatever the remaining public interest served by the water moratorium, those vested members of the waiting list are surely bearing the brunt of its economic burden for the entire community. And because they are not yet connected to water or sewer service, the members of the waiting list enjoy none of the benefits.

In California, the issue is always more complicated when water is involved.

Under California law, potential water use is not a property right. "[A] potential water user does not possess any absolute right to be afforded water service . . . "

Bank of America Nat'l Trust & Sav. Asso. v. Summerland County Water Dist. (9th Cir. 1985) 767 F.2d 544, *citing* Swanson v. Marin Municipal Water District, 56 Cal. App. 3d 512, 522, 128 Cal. Rptr. 485, 491 (1976).

However, in Lockary v. Kayfetz (9th Cir. 1990) 917 F.2d 1150, a Ninth Circuit Court of Appeals case cited by attorney William Walter in his recent letter on Mr. Hather's behalf, the court reversed a grant of summary judgement and allowed plaintiffs to proceed on a constitutional takings claim when their property value was impaired by a water moratorium.

Withholding available water from land zoned exclusively for residential use might interfere with the landowners' reasonable investment-backed expectations by preventing all practical use of that land. That the [plaintiffs] can still walk on, or ride a bike on, or look at their land does not, at this preliminary stage of the case, reassure us to the contrary. In this context, assuming the [plaintiffs] can show that sufficient water was available, then [the utility's] water moratorium may indeed constitute more than a mere reduction in property value.

Id. at 1155 (citations omitted). The court went on to explain that the key question was whether there actually was an ongoing water shortage; if the emergency that occasioned the moratorium had been rectified then it was more likely that the refusal to allow new hookups was arbitrary. Note that the plaintiffs in Lockary owned hundreds of acres of undeveloped land in Marin County. They truly could use their land for outdoor recreation. Mr. Hather owns a 1.1-acre vacant lot in the middle of a subdivision, surrounded by apartment complexes.

San Simeon's water emergency is over, yet the moratorium endures indefinitely. Mr. Hather has no economically viable use for his land without a Will-Serve Letter. His claim of a constitutional taking should be seriously considered by the Board and the provisions of Ordinance No. 102 prohibiting him from obtaining a Will-Serve Letter should be disregarded as to his Avonne Avenue property.

Granting Mr. Hather's Hardship Application Qualifies for the Common Sense CEQA Exemption

Discretionary acts that are otherwise subject to environmental review under the California Environmental Quality Act may be exempted from its provisions if they fall into one or more statutory or categorical exemptions, or if "it can be seen with certainty that there is no possibility that the activity in question may

have a significant effect on the environment.” 14 CCR 15061. This so-called “common sense” exemption from CEQA comes into play when, based on evidence and factual evaluation of the proposed activity, the lead agency determines that there can logically be no impact on the environment. Muzzy Ranch Co. v. Solano County Airport Land Use Com. (2007) 41 Cal.4th 372, 385.

Before Mr. Hather can build any structure or facility capable of connecting to water and sewer services, he will need to obtain a number of permits and approvals from the County of San Luis Obispo. Any project proposal will be subject to all necessary environmental review. Additionally, because the project falls within the Coastal Zone, it will also be subject to provisions of the California Coastal Act.

Issuing a Will-Serve Letter will have no actual effect independent of the larger project approval and permitting process, all of which will be subject to the provisions of CEQA. The granting of a Will-Serve Letter to Mr. Hather will have no impact on the environment and therefore qualifies for the Common-Sense Exemption.

CONCLUSION

The emergency that occasioned San Simeon’s water moratorium no longer exists, yet Robert Hather continues to suffer unnecessary financial hardship regarding his Avonne Avenue property. It is within the Board’s power to grant him immediate relief without waiting for a lengthy process to repeal Ordinance 102. The equities are strongly in favor of immediately issuing Mr. Hather a Will-Serve Letter.

Sincerely,

Jeffrey D. Stulberg

cc: Robert Hather – via email

EXHIBIT A

LEGAL DESCRIPTION

Real property in the City of San Simeon, County of San Luis Obispo, State of California, described as follows:

THAT PORTION OF LOT A OF THE PARTITION OF THAT PART OF THE SAN SIMEON RANCHO OWNED BY IRA VAN GORDON, SR., ACCORDING TO MAP RECORDED JULY 27, 1899, DESCRIBED AS FOLLOWS:

BEGINNING AT A POINT OF S. NO. 3 BEING THE SOUTHEAST CORNER OF THE ARBUCKLE TRACT IN SAID LOT A OF RANCHO SAN SIMEON AS SHOWN ON LICENSED SURVEYOR'S MAP RECORDED MAY 22, 1952, IN BOOK 6, AT PAGE 49 OF RECORD OF SURVEYS; THENCE NORTH 62 DEG. 29' EAST, 25.11 FEET TO A 1/2 INCH BAR SET IN THE CENTER LINE OF FORMER COUNTY ROAD NO. 3 NOW ABANDONED; THENCE NORTH 33 DEG. WEST ALONG SAID CENTER LINE, 488.58 FEET TO THE MOST NORTHERLY CORNER OF THE PROPERTY CONVEYED TO GRACE IRWIN, ET AL., BY DEED DATED MAY 11, 1955 AND RECORDED MAY 17, 1955 IN BOOK 804, AT PAGE 109 OF OFFICIAL RECORDS, SAID POINT ALSO BEING THE TRUE POINT OF BEGINNING; THENCE CONTINUING ALONG SAID CENTER LINE NORTH 33 DEG. WEST, 234.42 FEET TO A R. R. SPIKE; THENCE SOUTH 45 DEG. 51' WEST, 265.3 FEET TO THE CENTER LINE OF AVON AVENUE; THENCE SOUTH 44 DEG. 09' EAST ALONG SAID CENTER LINE, 230 FEET TO THE MOST WESTERLY CORNER OF THE PROPERTY CONVEYED TO GRACE IRWIN, AFORESAID; THENCE NORTH 45 DEG. 51' EAST ALONG THE NORTHWESTERLY LINE OF THE PROPERTY SO CONVEYED, 220 FEET TO THE TRUE POINT OF BEGINNING.

EXCEPTING THEREFROM THAT PORTION OF AVONNE AVENUE OFFERED FOR DEDICATION FOR PUBLIC USE BY INSTRUMENT RECORDED NOVEMBER 19, 1953 IN BOOK 734, PAGE 52 OF OFFICIAL RECORDS AND ACCEPTED BY THE SAN SIMEON ACRES COMMUNITY SERVICE DISTRICT, COUNTY OF SAN LUIS OBISPO BY RESOLUTION RECORDED NOVEMBER 15, 1962 IN BOOK 1211, PAGE 448 OF OFFICIAL RECORDS.

APN: 013-071-009

EXHIBIT B

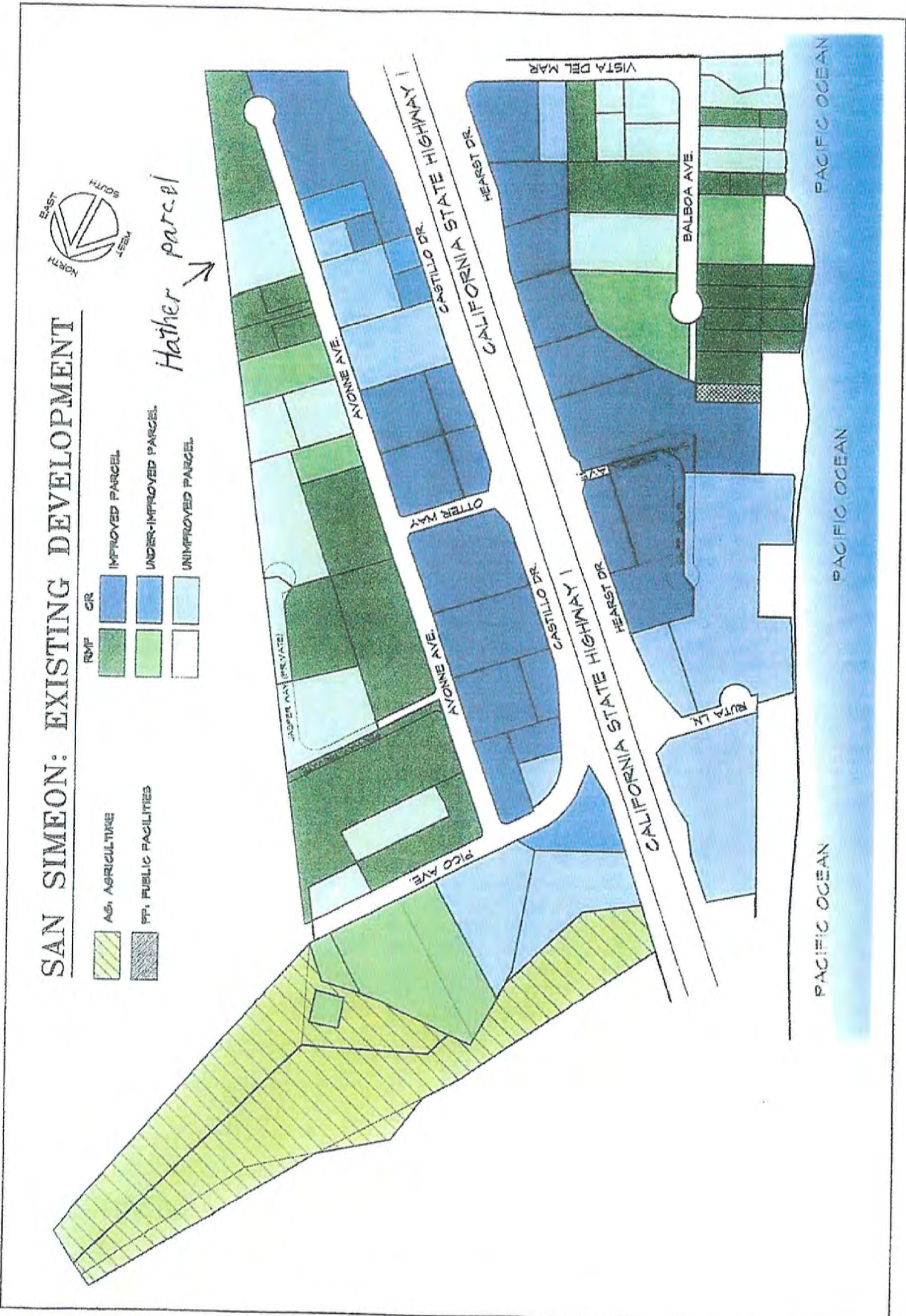

EXHIBIT C

2019099003

Notice of Completion & Environmental Document Transmittal

Mail to: State Clearinghouse, P.O. Box 3044, Sacramento, CA 95812-3044 (916) 445-0613
 For Hand Delivery/Street Address: 1400 Tenth Street, Sacramento, CA 95814

SCH #

Project Title: San Simeon CSD Community Water Tank Project
Lead Agency: San Simeon CSD **Contact Person:** Charlie Grace, General Manager
Mailing Address: 111 Pico Avenue **Phone:** 805-927-4778
City: San Simeon **Zip:** 93452 **County:** San Luis Obispo County

Project Location: County: San Luis Obispo City/Nearest Community: San Simeon
 Cross Streets: Pico Avenue Zip Code: 93452
 Longitude/Latitude (degrees, minutes and seconds): 35 ° 37 ' 11.64 " N / 121 ° 8 ' 29.04 " W Total Acres: 3.6 acre parcel
 Assessor's Parcel No.: 013-011-024 Section: Twp.: Range: Base:
 Within 2 Miles: State Hwy #, State Highway 1 Waterways: Pico Creek, Pacific Ocean
 Airports: NA Railways: NA Schools: NA

Document Type:
 CEQA: NOP Draft EIR NEPA: NOI Other: Joint Document
 Early Cons Supplement/Subsequent EIR EA Final Document
 Neg Dec (Prior SCH No.) Draft EIS Other:
 Mit Neg Dec Other:

Local Action Type:
 General Plan Update Specific Plan Rezone Annexation
 General Plan Amendment Master Plan Prezone Redevelopment
 General Plan Element Planned Unit Development Use Permit Coastal Permit
 Community Plan Site Plan Land Division (Subdivision, etc.) Other:

Development Type:
 Residential: Units _____ Acres _____
 Office: Sq.ft. _____ Acres _____ Employees _____
 Commercial: Sq.ft. _____ Acres _____ Employees _____
 Industrial: Sq.ft. _____ Acres _____ Employees _____
 Educational: _____
 Recreational: _____
 Water Facilities: Type _____ MGD _____
 Transportation: Type _____
 Mining: Mineral _____
 Power: Type _____ MW _____
 Waste Treatment: Type _____ MGD _____
 Hazardous Waste: Type _____
 Other: Public Facility/Community Water Tank

Project Issues Discussed in Document:
 Aesthetic/Visual Fiscal Recreation/Parks Vegetation
 Agricultural Land Flood Plain/Flooding Schools/Universities Water Quality
 Air Quality Forest Land/Fire Hazard Septic Systems Water Supply/Groundwater
 Archeological/Historical Geologic/Seismic Sewer Capacity Wetland/Riparian
 Biological Resources Minerals Soil Erosion/Compaction/Grading Growth Inducement
 Coastal Zone Noise Solid Waste Land Use
 Drainage/Absorption Population/Housing Balance Toxic/Hazardous Cumulative Effects
 Economic/Jobs Public Services/Facilities Traffic/Circulation Other:

Present Land Use/Zoning/General Plan Designation:
 Site is zoned "Agriculture" and "Residential Multi Family"

Project Description: (please use a separate page if necessary)
 The proposed project includes the installation of two new water storage tanks (400,000 gallons each), located approximately 530 feet northeast of the existing community reservoir, in order to meet community fire flow demands. Each new tank would be approximately 25.5 feet tall, with a diameter of 50 feet. Total disturbance includes 0.6 acres of earth disturbance for the proposed tank pad and access road. The project includes proposed infrastructure improvements for water pipelines to increase flow capacity per CalFire requirements. With the exception of approximately 300 feet of pipeline connecting the new tanks to the existing reservoir, all pipeline improvements will be installed within existing utility easements, utility conduits and otherwise previously disturbed areas.

State Clearinghouse Contact: (916) 445-0613
 State Review Began: 9-6-2019
 SCH COMPLIANCE 10-7-2019

Project Sent to the following State Agencies

- | | |
|---|--|
| <input checked="" type="checkbox"/> Resources | <input type="checkbox"/> Cal EPA |
| <input type="checkbox"/> Boating & Waterways | <input type="checkbox"/> ARB: Airport & Freight |
| <input type="checkbox"/> Central Valley Flood Prot. | <input type="checkbox"/> ARB: Transportation Projects |
| <input checked="" type="checkbox"/> Coastal Comm | <input checked="" type="checkbox"/> ARB: Major Industrial/Energy |
| <input type="checkbox"/> Colorado Rvr Bd | <input type="checkbox"/> Resources, Recycl. & Recovery |
| <input checked="" type="checkbox"/> Conservation | <input type="checkbox"/> SWRCB: Div. of Drinking Water |
| <input checked="" type="checkbox"/> CDFW # 4 | <input checked="" type="checkbox"/> SWRCB: Div. Drinking Wtr # 6 |
| <input type="checkbox"/> Cal Fire | <input type="checkbox"/> SWRCB: Div. Financial Assist. |
| <input checked="" type="checkbox"/> Historic Preservation | <input checked="" type="checkbox"/> SWRCB: Wtr Quality |
| <input checked="" type="checkbox"/> Parks & Rec | <input type="checkbox"/> SWRCB: Wtr Rights |
| <input type="checkbox"/> Bay Cons & Dev Comm. | <input checked="" type="checkbox"/> Reg. WQCB # 2 |
| <input type="checkbox"/> DWR | <input type="checkbox"/> Toxic Sub Ctrl-CTC |
| | Yth/Adlt Corrections |
| | <input type="checkbox"/> Corrections |
| | Independent Comm |
| <input type="checkbox"/> CalSTA | <input type="checkbox"/> Delta Protection Comm |
| <input type="checkbox"/> Aeronautics | <input type="checkbox"/> Delta Stewardship Council |
| <input checked="" type="checkbox"/> CHP | <input type="checkbox"/> Energy Commission |
| <input checked="" type="checkbox"/> Caltrans# 5 | <input checked="" type="checkbox"/> NAHC |
| <input type="checkbox"/> Trans Planning | <input type="checkbox"/> Public Utilities Comm |
| Other | <input type="checkbox"/> Santa Monica Bay Restoration |
| <input type="checkbox"/> Education | <input checked="" type="checkbox"/> State Lands Comm |
| <input type="checkbox"/> Food & Agriculture | <input type="checkbox"/> Tahoe Rgl Plan Agency |
| <input type="checkbox"/> HCD | |
| <input type="checkbox"/> OES | |
| <input type="checkbox"/> State/Consumer Svcs | <input type="checkbox"/> Conservancy |
| <input type="checkbox"/> General Services | |
| | Other: _____ |

Please note State Clearinghouse Number (SCH#) on all Comments
 2019099003
 SCH#: _____
 Please forward late comments directly to the Lead Agency

AQMD/APCD 29
 (Resources: 9, 7)

EXHIBIT D

EXHIBIT E

Reviewing Agencies Checklist

Lead Agencies may recommend State Clearinghouse distribution by marking agencies below with an "X". If you have already sent your document to the agency please denote that with an "S".

- | | |
|---|--|
| <input checked="" type="checkbox"/> Air Resources Board | <input checked="" type="checkbox"/> Office of Historic Preservation |
| <input type="checkbox"/> Boating & Waterways, Department of | <input type="checkbox"/> Office of Public School Construction |
| <input type="checkbox"/> California Emergency Management Agency | <input type="checkbox"/> Parks & Recreation, Department of |
| <input type="checkbox"/> California Highway Patrol | <input type="checkbox"/> Pesticide Regulation, Department of |
| <input checked="" type="checkbox"/> Caltrans District # <u>5</u> | <input type="checkbox"/> Public Utilities Commission |
| <input type="checkbox"/> Caltrans Division of Aeronautics | <input checked="" type="checkbox"/> Regional WQCB # <u>3</u> |
| <input type="checkbox"/> Caltrans Planning | <input type="checkbox"/> Resources Agency |
| <input type="checkbox"/> Central Valley Flood Protection Board | <input type="checkbox"/> Resources Recycling and Recovery, Department of |
| <input type="checkbox"/> Coachella Valley Mtns. Conservancy | <input type="checkbox"/> S.F. Bay Conservation & Development Comm. |
| <input checked="" type="checkbox"/> Coastal Commission | <input type="checkbox"/> San Gabriel & Lower L.A. Rivers & Mtns. Conservancy |
| <input type="checkbox"/> Colorado River Board | <input type="checkbox"/> San Joaquin River Conservancy |
| <input type="checkbox"/> Conservation, Department of | <input type="checkbox"/> Santa Monica Mtns. Conservancy |
| <input type="checkbox"/> Corrections, Department of | <input type="checkbox"/> State Lands Commission |
| <input type="checkbox"/> Delta Protection Commission | <input type="checkbox"/> SWRCB: Clean Water Grants |
| <input type="checkbox"/> Education, Department of | <input checked="" type="checkbox"/> SWRCB: Water Quality |
| <input type="checkbox"/> Energy Commission | <input type="checkbox"/> SWRCB: Water Rights |
| <input checked="" type="checkbox"/> Fish & Game Region # <u>4</u> | <input type="checkbox"/> Tahoe Regional Planning Agency |
| <input type="checkbox"/> Food & Agriculture, Department of | <input type="checkbox"/> Toxic Substances Control, Department of |
| <input type="checkbox"/> Forestry and Fire Protection, Department of | <input checked="" type="checkbox"/> Water Resources, Department of |
| <input type="checkbox"/> General Services, Department of | Other: _____ |
| <input type="checkbox"/> Health Services, Department of | Other: _____ |
| <input type="checkbox"/> Housing & Community Development | |
| <input checked="" type="checkbox"/> Native American Heritage Commission | |

Local Public Review Period (to be filled in by lead agency)

Starting Date September 9, 2019 Ending Date October 9, 2019

Lead Agency (Complete if applicable):

Consulting Firm: <u>Oliveira Environmental Consulting, LLC</u>	Applicant: <u>San Simeon Community Services District</u>
Address: <u>3155 Rose Avenue</u>	Address: <u>111 Pico Avenue</u>
City/State/Zip: <u>San Luis Obispo, CA 93401</u>	City/State/Zip: <u>San Simeon, CA 93452</u>
Contact: <u>Jeff Oliveira, Principal Environmental Planner</u>	Phone: <u>805-927-4778</u>
Phone: <u>805-234-7393</u>	

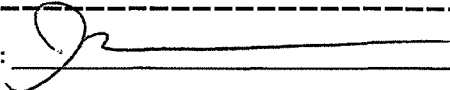
Signature of Lead Agency Representative:  Date: 9/4/2019

Authority cited: Section 21083, Public Resources Code. Reference: Section 21161, Public Resources Code.



COUNTY OF SAN LUIS OBISPO
DEPARTMENT OF PLANNING & BUILDING
Trevor Keith *Director of Planning & Building*

Tuesday, October 15, 2019

HATHER ROBERT K TRE ETAL
3675 SEQUOIA DR
SAN LUIS OBISPO, CA 93401

SUBJECT: Pre-Application PRE2019-00111

Dear Sir/Madam,

A pre-application meeting was held on Tuesday, September 10, 2019 to discuss the following proposed project:

15-unit multi-family residences

Please note that the pre-application fee can be credited to any discretionary permit application if one is applied for within six months of the meeting date.

Sincerely,

Donna Hernandez
Administrative Assistant

Meeting Date: Tuesday, September 10, 2019

Meeting Attendees:

Don Moore (Staff)

Kerry Brown (Staff)

Mike Stoker (Staff)

Rene Brill (Staff)

Young Choi (Staff)

Meeting Notes:

Project Description: 15-unit multi-family subdivision

Building:

"Carriage Units" CBC Chapter 11 may get you out of ADA requirement.

Applicant should decide how the units would be sold and check with Building department for Building Requirement. Different units may trigger different building requirements. (commonly owned vs. individually owned)

Public Works:

North Coast Road Improvement Fees, Traffic Engineer Report required. Depending on how the units are being sold, RIF fee may be calculated differently.

Curb Gutter and Sidewalk required

Drainage Plan required

Planning:

Different sets of ordinances apply whether the applicant is requesting Planned Dev, or townhome-style development.

LUO 23.04.092 (Affordable Housing Requirement) - 15% of the units shall be provided as affordable housing for persons and families of low or moderate income. For questions regarding Affordable Housing Requirements, please contact Ted Bench tbench@co.slo.ca.us

805 781 5701

(15) 2-Bedroom units

Parking required: Resident - 1.5 per 2-bedroom unit; Guest - 1 space plus 1 for each 4 units

27 parking spaces needed

Maximum Floor Area 48%

Minimum Open Area 45%

A Will-serve for water and sewer from SSCSD will be required in order to apply for the permits.



COUNTY OF SAN LUIS OBISPO
DEPARTMENT OF PLANNING & BUILDING
Trevor Keith *Director of Planning & Building*

Tuesday, October 15, 2019

HATHER ROBERT K TRE ETAL
3675 SEQUOIA DR
SAN LUIS OBISPO, CA 93401

SUBJECT: Pre-Application PRE2019-00111

Dear Sir/Madam,

A pre-application meeting was held on Tuesday, September 10, 2019 to discuss the following proposed project:

15-unit multi-family residences

Please note that the pre-application fee can be credited to any discretionary permit application if one is applied for within six months of the meeting date.

Sincerely,

Donna Hernandez
Administrative Assistant

Meeting Date: Tuesday, September 10, 2019

Meeting Attendees:

Don Moore (Staff)

Kerry Brown (Staff)

Mike Stoker (Staff)

Rene Brill (Staff)

Young Choi (Staff)

Meeting Notes:

Project Description: 15-unit multi-family subdivision

Building:

"Carriage Units" CBC Chapter 11 may get you out of ADA requirement.

Applicant should decide how the units would be sold and check with Building department for Building Requirement. Different units may trigger different building requirements. (commonly owned vs. individually owned)

Public Works:

North Coast Road Improvement Fees, Traffic Engineer Report required. Depending on how the units are being sold, RIF fee may be calculated differently.

Curb Gutter and Sidewalk required

Drainage Plan required

Planning:

Different sets of ordinances apply whether the applicant is requesting Planned Dev, or townhome-style development.

LUO 23.04.092 (Affordable Housing Requirement) - 15% of the units shall be provided as affordable housing for persons and families of low or moderate income. For questions regarding Affordable Housing Requirements, please contact Ted Bench
tbench@co.slo.ca.us

805 781 5701

(15) 2-Bedroom units

Parking required: Resident - 1.5 per 2-bedroom unit; Guest - 1 space plus 1 for each 4 units

27 parking spaces needed

Maximum Floor Area 48%

Minimum Open Area 45%

A Will-serve for water and sewer from SSCSD will be required in order to apply for the permits.

PROJECT STATISTICS: SITE AMENITIES

- BBQ AREA
- PLAY AREA
- 2 ACCESS DRIVEWAYS TO PROPERTY
- COMMUNITY MAILBOX



HATHER MULTI-FAMILY

SITE PLAN
SCALE: 1/16" = 1'-0"

Isaman design, Inc.

ARCHITECT
2420 Broad Street
San Luis Obispo, CA 93401
Phone: 805/544.5672
Fax: 805/544.5642
www.isamandesign.com



PROJECT STATISTICS: UNITS 8-15

1ST FLOOR CONDITIONED SF:	99 SF
2ND FLOOR CONDITIONED SF:	886 SF
TOTAL CONDITIONED SF:	985 SF
2-CAR GARAGE:	756 SF
DECK:	250 SF
BACKYARD:	390 - 520 SF

PROJECT STATISTICS: UNITS 1-7

1ST FLOOR CONDITIONED SF:	99 SF
2ND FLOOR CONDITIONED SF:	871 SF
TOTAL CONDITIONED SF:	970 SF
2-CAR GARAGE:	756 SF
DECK:	250 SF
BACKYARD:	520 - 650 SF



3B 8-15: SECOND FLOOR
SCALE: 1/8" = 1'-0"



2B 1-7: SECOND FLOOR
SCALE: 1/8" = 1'-0"

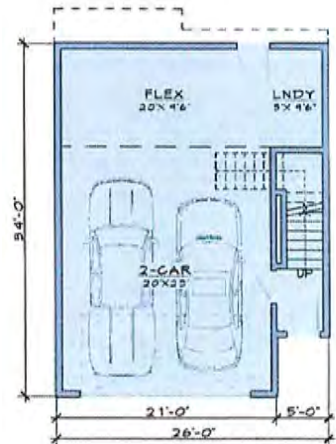

3A 8-15: FIRST FLOOR
SCALE: 1/8" = 1'-0"

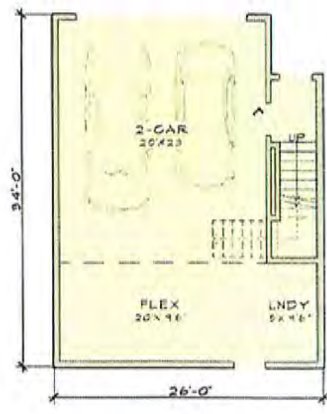

2A 1-7: FIRST FLOOR
SCALE: 1/8" = 1'-0"



Stulberg Correspondence January 25, 2021



January 25, 2021

Via Email & Regular Mail

Board of Directors
San Simeon Community Services District
c/o Jeffrey A. Minnery
Adamski Moroski Madden
Cumberland & Green LLP
PO Box 3835
San Luis Obispo, CA 93403-3835

Re: Addendum to Robert Hather's Hardship Application

Dear Sirs and Madams:

Robert Hather's Hardship Application for relief from the water moratorium will come before you again at your February 11, 2021 meeting. Mr. Hather, founder of Lifewater Drilling¹, appreciates the complex water issues facing the CSD better than most. However, in order to comply with sections V and VI of CSD Ordinance No. 102, ***the Board must consider Mr. Hather's November 24, 2020 Hardship Application separately from any ongoing discussions regarding modifying or lifting the moratorium*** and without further delay. The Board must also consider separately from the Hardship Application whether Ordinance 102 has caused a regulatory taking of Mr. Hather's property.

**Consideration of Mr. Hather's Hardship Application Must
Be Based on His Individual Property and Circumstances**

By its own terms, section V of Ordinance No. 102 requires that Mr. Hather's application be considered solely based on his individual circumstances, regardless of the timeline for lifting the moratorium or the theoretical merits of others on the waiting list who have not indicated that they are facing hardship.

While the Board may consider factors not explicitly enumerated in section V, the ordinance limits that scope to "[s]uch other factors as may be significant ***relative to the individual property and circumstances.***" Any discussion of the Water Moratorium itself is irrelevant to Mr. Hather's Hardship Application. So too is any discussion of others on the waiting list, none of whom are currently seeking relief. The fact that seven other parties² have spent longer on the waiting list than Mr. Hather does not necessarily mean they are facing an equally urgent economic hardship under the Moratorium. Mr. Hather is an individual nearing retirement whose

¹ Lifewater Drilling was founded in 2008 to help developing countries access potable water.

² According to CSD Resolution No. 20-426 there are seven parties who have been on the waiting list longer than Mr. Hather, including two motel projects with 35 and 145 rooms respectively.

ability to access his investments is being severely impeded; at least three of the list members with greater seniority are corporations.

Furthermore, granting Mr. Hather's Hardship Application would actually increase equity by ensuring that the economic burden of the Moratorium does not fall more harshly on one waiting list member than another. We are not aware of any other list members who have submitted Hardship Applications. If they were to do so, the terms of section V would require each to be evaluated based on its own merits. While it is natural to think of cumulative impacts, that analysis is misplaced in the context of a Hardship Application which by its nature is focused only on the individual property for which relief is sought.³

Further Delay is Contrary to the Intent of Ordinance No. 102

The CSD added the Hardship Application process to the Water Moratorium in 2006 when Ordinance No. 102 replaced Ordinance No. 66, likely anticipating that such situations as Mr. Hather's would inevitably arise under an indefinite moratorium. The process seems intended to serve as a release valve during the duration of the moratorium for in case any property owner is forced to bear an unfair and unsustainable—in light of the applicant's own particular financial situation—share of its economic burden. Postponing the consideration of Mr. Hather's Hardship Application until the moratorium is lifted frustrates this intent and renders the entire section moot.

Whether the Provisions of Ordinance 102 Effect a Regulatory Taking of Mr. Hather's Property Must Also Be Considered

In addition to considering the Hardship Application, the CSD Board must also still consider whether the provisions of Ordinance No. 102 are preventing Mr. Hather from economically viable use of his property. If they are, section VI requires that such provisions "be disregarded to the extent necessary to avoid such unconstitutional taking." As detailed in Mr. Hather's November 24, 2020 Hardship Application letter, the Moratorium is currently preventing all economically beneficial use of Mr. Hather's property. There is a strong case that a categorical regulatory taking of his property has occurred. Mr. Hather again requests that the CSD hold an "up or down" vote on the merits of his individual circumstances as set forth in the original petition, and as supplemented in communication with the Board and Legal Counsel.

Sincerely,

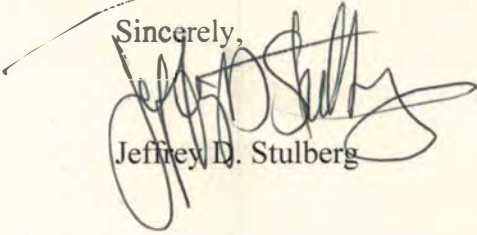

Jeffrey D. Stulberg

cc: Robert Hather – via email

³ Any future development project proposed on Mr. Hather's property will require a permit from the County of San Luis Obispo and be subject to appropriate environmental review throughout that permitting process. If the granting of the Hardship Application is not ministerial, it would still logically qualify for a Common-Sense CEQA exemption because the will-serve letter by itself can have no possible impact on the environment.

Hather Correspondence

March 8, 2021

Mar 8 2021

To Elected SSCSD Board,

I am requesting a Conditional Will Serve letter from the San Simeon Community Service District. My intent with the property is to build 15 residential units including two designated affordable housing units and one residence for myself and children and grandchildren on the Avonne property. I have made this request on multiple occasions under the hardship exemption provided in Ordinance 102 Section V. I will be 68 years old in May, still working, with a home mortgage on my San Luis Obispo residence. With my sole combined monthly Social Security and one rental property income without the use of use of my San Simeon property I will not be able to retire with an equal standard of living. I believe the exemption provided in Ordinance 102 Section V was created with the legislative intent of providing relief for tax paying property owners with such a circumstance as mine. This memo follows a request by district counsel Jeff Minery to my attorney Jeff Stulberg requesting that I provide clarification to the BOD establishing and immediate and continuous impact on my ability to fully retire. Please provide my request for a conditional will serve letter so that the land can proceed with a County application for development.

Robert Hather
3675 Sequoia Dr.
San Luis Obispo, CA 93401
805 459-1841
bobhather@gmail.com

Stulberg Correspondence May 3, 2021



May 3, 2021

VIA U.S. MAIL AND EMAIL

Board of Directors
San Simeon Community Services District
c/o Jeffrey A. Minnery
Adamski Moroski Madden
Cumberland & Green LLP
PO Box 3835
San Luis Obispo, CA 93403-3835

*Re: Notice of Intent by Robert Hather to Bring Suit Against San Simeon
Community Services District*

Honorable Directors:

As you are aware, this office represents Robert Hather, on whose behalf I provide you with this notice of Mr. Hather's intent to commence litigation against the San Simeon Community Services District (SSCSD) unless the District immediately acts on Mr. Hather's Hardship Application. My firm was retained by Mr. Hather in October 2020, in the hope that a resolution could be had without the necessity of litigation. It is now clear that those efforts were pointless, and litigation is the last and only option that makes sense.

As you know, SSCSD's Water Moratorium has prevented Robert Hather from fulfilling his dream of developing his 1.1 acre vacant lot (San Luis Obispo County Assessor's Parcel Number 013-071-009) on Avonne Avenue in San Simeon. Mr. Hather has exhausted every potential form of equitable relief and/or administrative remedy. Mr. Hather filed a Hardship Application for relief from the Water Moratorium pursuant to Section V of the District's Ordinance No. 102, which as set forth below, the District has refused to consider.

Mr. Hather has been actively seeking relief from the moratorium for six months. In October 2020 he requested a hearing at the November 10, 2020 meeting. He submitted a formal Hardship application on November 24, 2020 to be considered by the Board at its December 9, 2020 meeting. The Application was continued to the January 14, 2021 meeting, where, following a discussion that ignored the merits of the Application and instead focused on unrelated issues, the Board continued to a special meeting on February 9, 2021. The Board did not take any final action on the Application at that meeting, or at any other forum since.

The District's failure to act on the Hardship Application is apparently based on the District's decision to focus on the broader question of lifting or modifying the moratorium. The District's own regulations, however, do not give the Board the discretion to avoid acting on a Hardship Application pending a final decision to modify or lift the moratorium. The Board's decision not

May 3, 2021

Page 2

to adjudicate the Hardship Application, therefore, was unreasonable, unlawful and a clear abuse of discretion.

This Board's decision not to act on the Hardship Application is detrimental to the public health and welfare and against the public policy of the State of California because Mr. Hather has been pursuing plans to develop much needed multi-family residential units on his San Simeon property. The District's refusals to issue a will-serve letter have essentially stalled the development process because without the will-serve letter, the County will not deem the permit application complete. The County residents desperately need exactly the type of moderate and affordable-by-design residential units that Mr. Hather's project is intended to provide.

The District's refusal to act on Mr. Hather's Hardship Application is particularly egregious because as the District's own data clearly demonstrate that owing to the combined impact of increased conservation, the Water Reuse Project and a new Reverse Osmosis plant that has been operational since 2016, a water moratorium is patently no longer justified. The District's February 9, 2021 Staff Report admits that "objective evidence compels a conclusion that water is now available for new development." Accordingly, the District's failure to rescind the "emergency" moratorium is in violation of Water Code Section 355, according to which, an emergency moratorium can only remain in effect "until the supply of water available for distribution ... has been replenished or augmented."

The District's attempt to evade environmental review of a decision to lift or modify the moratorium by authorizing the preparation of an Urban Water Management Plan (UWMP) is a dubious legal gambit that does not justify the District's failure to act on the Hardship Application. The preparation of an UWMP does not provide the District with any legal cover to avoid acting on Mr. Hather's Hardship application, and will not, in any event, legally justify the District's apparent decision to evade environmental review as required by the California Environmental Quality Act (CEQA).

Mr. Hather continues to incur damages and suffer negative economic impacts as a direct result of the District's unlawful failure to lift the moratorium and to act on his Hardship application. Notwithstanding the District's unreasonable and unlawful failure to act, Mr. Hather has continued to maintain his property, abate fire danger, and pay property taxes. Mr. Hather also continues to suffer significant economic lost opportunity damages.

Ironically, as a founder of Lifewater Drilling Technology, Mr. Hather would have been able to dig his own well to obtain water necessary to support the development had it not been for the fact that the SSCSD had already secured the groundwater rights underlying the entire area. This means that while the District and its current customers benefit from Mr. Hather's groundwater rights, he is deprived of the same benefit.

Unless the District provides immediate assurances that it will act on the Hardship Application forthwith, Mr. Hather will commence litigation in federal court seeking damages and injunctive relief. The lawsuit will seek damages for taking of his property because the District's

May 3, 2021

Page 3

unreasonable and unlawful refusal to provide water and sewer services to his property have indefinitely denied him all economically beneficial or productive use of his land. *Lucas v. S. C. Coastal Council*, 505 U.S. 1003, 112 S. Ct. 2886 (1992). Moreover, the fact that Mr. Hather has owned and maintained the property for more than 15 years, and that the majority of the people who enjoy beneficial effects of the Water Moratorium are not similarly burdened may also support a partial takings claim under the Penn Central factors. *Penn Cent. Transp. Co. v. New York City*, 438 U.S. 104 (1978). The fact that Mr. Hather acquired title after the moratorium went into effect is not a bar to his claim. *Palazzolo v. Rhode Island*, 533 U.S. 606 (2001). Nor is the ostensibly temporary nature of the restraint. *First English Evangelical Lutheran Church v. Los Angeles County*, 482 U.S. 304 (1987)

If Mr. Hather is forced to commence litigation, he will also be seeking a writ of mandate directing the District to lift the moratorium, or at a minimum, to act on his Hardship Application.

Very truly yours,

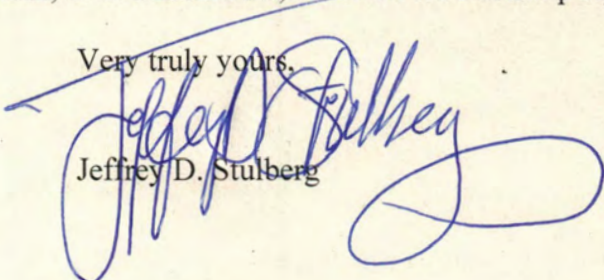
Jeffrey D. Stulberg

JDS/al

cc: Robert Hather
Jeffrey A. Minnery, Esq.
Babak Naficy, Esq.

5. A. ii. SUPERINTENDENT REPORT
Jerry Copeland
Facilities Update for May 2021



SUPERINTENDENT'S REPORT

Item 5.A.ii

Prepared by: Jerry Copeland

1. Wastewater Treatment Plant

- All sampling, testing and reporting at the Wastewater Treatment Plant was performed as required by the RWQCB.
- The monthly report was submitted to the SWRCB.
- Annual maintenance and minor repairs were made to Reactor and Clarifier #2.
- The motor on Equalization Basin Pump #1 was replaced.
- The standby generator housing at the WWTP was patched, primed and repainted. Quarterly maintenance was also performed.
- Flow meters around the plant were calibrated by Telstar Instruments.
- Annual Laboratory Proficiency Testing was performed.
- Two loads of sludge were hauled away.

2. Water Treatment and Distribution System

- All routine sampling and testing was performed.
- The monthly report was submitted to the State Water Resources Control Board (SWRCB), Division of Drinking Water (DDW).
- The Electronic Annual Report was submitted to SWRCB, DDW.
- Filter operations continue daily.
- Quarterly maintenance on the standby generator at the wells was performed.
- Monthly water meter reading was performed.

3. District and Equipment Maintenance

- Annual weed abatement was performed around the District easements. Weed abatement was also performed at all the District facilities.
- Staff continues with all the scheduled preventive maintenance for all the equipment at the facilities. We are recording all these activities.

San Simeon Community Services District

Superintendent's Report

May 2021

MONTHLY DATA REPORT

Date	Day	Wastewater Influent Daily Flow	Wastewater Effluent Daily Flow	Well 1 Total Daily Produced	Well 2 Total Daily Produced	Total Daily Water Produced	R.O. Daily Influent Flow	R.O. Daily Effluent Flow	R.O. Daily Brine Flow	Distribution Chloride	Chloride Wells 1	Chloride Wells 2	Recycled Water Distributed	Water Level Well 1	Water Level Well 2	Rainfall in Inches	State Flows
05/01/21	Saturday	68,216	71,730	27,003	78,989	105,992	0	0	0	-	-	-	0	10.1	9.9	0.00	1,626
05/02/21	Sunday	61,274	63,810	52,061	8,153	60,214	0	0	0	-	-	-	0	10.2	9.9	0.00	2,796
05/03/21	Monday	54,164	55,080	2,842	48,919	51,762	0	0	0	-	-	-	0	10.2	9.9	0.00	2,797
05/04/21	Tuesday	56,339	54,940	60,663	8,527	69,190	0	0	0	-	-	-	0	10.1	9.9	0.00	1,227
05/05/21	Wednesday	33,229	43,400	9,350	47,722	57,072	0	0	0	42	32	<30	0	10.2	9.9	0.00	1,445
05/06/21	Thursday	49,222	52,000	45,329	3,890	49,218	0	0	0	-	-	-	0	10.2	9.8	0.00	1,513
05/07/21	Friday	54,849	61,480	19,523	62,383	81,906	0	0	0	-	-	-	0	10.2	9.9	0.00	1,291
05/08/21	Saturday	56,339	62,830	58,419	15,035	73,454	0	0	0	-	-	-	0	10.2	9.9	0.00	1,268
05/09/21	Sunday	56,341	64,750	10,173	65,824	75,997	0	0	0	-	-	-	0	10.2	9.9	0.00	3,351
05/10/21	Monday	47,939	50,000	39,270	2,992	42,262	0	0	0	-	32	<30	0	10.2	10.0	0.00	2,810
05/11/21	Tuesday	37,654	42,300	4,638	53,482	58,120	0	0	0	-	-	-	0	10.2	9.9	0.00	1,236
05/12/21	Wednesday	46,965	52,150	48,994	3,890	52,884	0	0	0	-	-	-	0	10.2	9.9	0.00	1,494
05/13/21	Thursday	33,798	38,040	6,582	52,884	59,466	0	0	0	-	-	-	0	10.2	9.9	0.00	1,561
05/14/21	Friday	43,226	55,220	56,698	12,716	69,414	0	0	0	-	-	-	0	10.2	9.9	0.00	1,082
05/15/21	Saturday	64,203	73,970	11,295	57,147	68,442	0	0	0	-	-	-	0	10.2	10.0	0.00	1,567
05/16/21	Sunday	56,732	66,730	79,363	2,394	81,756	0	0	0	-	-	-	0	10.2	10.0	0.00	5,124
05/17/21	Monday	53,962	58,330	5,386	54,080	59,466	0	0	0	38	-	-	0	10.3	9.9	0.00	1,257
05/18/21	Tuesday	37,489	49,080	54,080	2,992	57,072	0	0	0	-	-	-	0	10.2	9.9	0.00	1,618
05/19/21	Wednesday	39,648	54,780	12,118	47,049	59,167	0	0	0	-	-	-	0	10.3	10.0	0.00	1,123
05/20/21	Thursday	41,684	53,990	46,301	3,366	49,667	0	0	0	32	34	<30	0	10.3	10.0	0.00	1,848
05/21/21	Friday	50,614	57,490	0	57,372	57,372	0	0	0	-	-	-	0	10.3	10.0	0.00	1,788
05/22/21	Saturday	63,417	70,510	76,072	0	76,072	0	0	0	-	-	-	0	10.3	10.0	0.00	1,825
05/23/21	Sunday	62,198	60,810	6,283	88,563	94,846	0	0	0	-	-	-	0	10.3	9.9	0.00	3,195
05/24/21	Monday	52,209	65,010	59,541	10,846	70,387	0	0	0	-	-	-	0	10.3	10.0	0.00	1,976
05/25/21	Tuesday	44,611	53,640	2,020	57,671	59,690	0	0	0	-	-	-	0	10.3	10.0	0.00	1,544
05/26/21	Wednesday	39,987	57,250	50,415	4,114	54,529	0	0	0	-	-	-	0	10.3	10.0	0.00	2,245
05/27/21	Thursday	36,715	41,630	15,110	53,931	69,040	0	0	0	-	30	<30	0	10.2	9.9	0.00	1,095
05/28/21	Friday	55,909	64,470	52,360	13,015	65,375	0	0	0	-	-	-	0	10.3	10.0	0.00	1,609
05/29/21	Saturday	67,950	72,390	16,830	65,974	82,804	0	0	0	-	-	-	0	10.3	10.0	0.00	5,244
05/30/21	Sunday	81,349	84,600	82,130	13,763	95,894	0	0	0	-	-	-	0	10.3	10.1	0.00	5,071
05/31/21	Monday	71,485	73,870	0	72,257	72,257	0	0	0	-	-	-	0	10.3	10.0	0.00	3,880
TOTALS		1,619,717	1,826,280	1,010,847	1,069,939	2,080,786	0	0	0				0			0.00	67,506
Average		52,249	58,912	32,608	34,514	67,122	0	0	0	37	32	<30	0	10.2	9.9	0.00	2,178
Minimum		33,229	38,040	0	0	42,262	0	0	0	32	30	<30	0	10.1	9.8	0.00	1,082
Maximum		81,349	84,600	82,130	88,563	105,992	0	0	0	42	34	<30	0	10.3	10.1	0.00	5,244

DATA SUMMARY SHEET

2021													
	Jan-21	Feb-21	Mar-21	Apr-21	May-21	Jun-21	Jul-21	Aug-21	Sep-21	Oct-21	Nov-21	Dec-21	Total for 2021
Wastewater Influent	2,399,103	1,705,622	1,820,175	1,763,875	1,619,717								9,308,492
Wastewater Final Effluent (Month Cycle)	2,546,130	1,747,000	1,874,290	1,827,000	1,826,280								9,820,700
Adjusted Wastewater Influent (- State Flow)	2,148,485	1,645,420	1,765,245	1,705,967	1,552,211								8,817,328
Water Produced (month cycle)	1,851,150	1,682,402	1,907,250	2,114,147	2,080,786								9,635,736
Sewer Influent/Water Produced Ratio	1.30	1.05	0.95	0.83	0.78								N/A
Adjusted Sewer/Water Produced Ratio	1.16	0.95	0.93	0.81	0.75								N/A
Well 1 Water Production	90,358	3,590	101,952	972,774	1,010,847								2,179,522
Well 2 Water Production	1,760,792	1,678,811	1,805,298	1,141,373	1,069,939								7,456,214
Total Well Production	1,851,150	1,682,402	1,907,250	2,114,147	2,080,786								9,635,736
Water Well 1 Avg Depth to Water	10.6	9.9	9.8	10.1	10.2								N/A
Water Well 2 Avg Depth to Water	10.4	9.6	9.5	9.8	9.9								N/A
Average Depth to Water of Both Wells	10.5	9.7	9.7	10.0	10.1								N/A
Change in Average Depth to Water from 2020	+0.2	-0.4	-0.3	0.0	-0.2								N/A
Average Chloride mg/L at the Wells	352	169	77	41	31								N/A
State Wastewater Treated	250,618	60,202	125,914	57,908	67,506								562,148
State % of Total WW Flow	10%	4%	7%	3%	4%								N/A
Recycled Water Sold (Gallons)	0	0	0	0	0								0
Biosolids Removal (Gallons)	0	4,500	0	4,500	9,000								18,000
WW Permit Limitation Exceeded	0	0	0	0	0								0
RW Permit Limitation Exceeded	0	0	0	0	0								0
Constituent Exceeded	None	None	None	None	None								N/A
Sample Limit	N/A	N/A	N/A	N/A	N/A								N/A
Sample Result	N/A	N/A	N/A	N/A	N/A								N/A
2020													
	Jan-20	Feb-20	Mar-20	Apr-20	May-20	Jun-20	Jul-20	Aug-20	Sep-20	Oct-20	Nov-20	Dec-20	Total for 2020
Wastewater Influent	2,215,755	1,971,958	1,944,913	1,583,618	1,850,716	2,266,319	2,341,110	2,516,424	1,858,385	1,825,386	1,542,483	1,305,557	23,222,624
Wastewater Final Effluent (Month Cycle)	2,168,690	1,922,920	1,846,450	1,555,350	1,707,500	2,045,070	2,304,980	2,397,730	1,907,070	1,915,400	1,661,370	1,431,330	22,863,860
Adjusted Wastewater Influent(- State Flow) *	1,958,507	1,780,122	1,818,999	1,500,460	1,748,006	2,201,429	2,262,301	2,440,274	1,798,005	1,763,948	1,490,514	1,257,657	22,020,222
Water Produced (month cycle)	1,843,670	1,872,693	1,514,688	1,215,724	1,962,303	2,261,129	2,673,502	2,726,684	2,321,568	2,242,803	1,894,160	1,785,252	24,314,177
Sewer Influent/Water Produced Ratio	1.20	1.05	1.28	1.31	0.94	1.00	0.88	0.92	0.80	0.81	0.81	0.73	N/A
Adjusted Sewer/Water Ratio	0.94	0.95	1.20	1.24	0.89	0.91	0.85	0.90	0.78	0.79	0.79	0.71	N/A
Average Depth of Both Wells	10.3	10.1	10.0	10.0	10.4	10.2	9.9	10.4	11.3	12.2	12.8	12.5	N/A
Change in Average Depth to Water from 2019	+1.0	+1.1	+0.7	-0.2	+0.2	+0.1	+0.1	+0.1	+0.6	+0.5	+0.6	+1.1	N/A
Average Chloride mg/L at the Wells	32	32	32	-	-	-	-	-	-	<30	<30	55	N/A
State Wastewater Treated	257,248	191,836	125,914	83,158	102,710	64,890	78,809	76,150	60,380	61,438	51,969	47,900	1,202,402
State % of Total WW Flow	12%	10%	6%	5%	6%	3%	3%	3%	3%	3%	3%	4%	N/A
Recycled Water Sold (Gallons)	0	0	0	0	0	0	0	0	0	0	0	0	0
Biosolids Removal (Gallons)	4,500	9,000	9,000	0	4,500	4,500	9,000	0	4,500	4,500	4,500	4,500	58,500
WW Permit Limitation Exceeded	0	0	0	0	0	0	0	0	0	0	0	0	N/A
RW Permit Limitation Exceeded	0	0	0	0	0	0	0	0	0	0	0	0	N/A
Constituent Exceeded	None	None	None	None	None	None	None	None	None	None	None	None	N/A
Sample Limit	N/A	N/A	N/A	N/A	N/A	N/A	N/A	N/A	N/A	N/A	N/A	N/A	N/A
Sample Result	N/A	N/A	N/A	N/A	N/A	N/A	N/A	N/A	N/A	N/A	N/A	N/A	N/A

San Simeon Community Services District

Superintendent's Report

May 2021

	Jan	Feb	Mar	April	May	June	July	Aug	Sept	Oct	Nov	Dec
Well Average Depth 2017	8.1	8.0	10.0	10.0	9.9	9.7	10.1	10.4	10.5	11.0	11.8	11.8
Well Average Depth 2018	10.8	10.3	9.7	10.3	10.4	10.1	10.4	11.0	11.9	12.4	12.8	9.9
Well Average Depth 2019	9.3	9.0	9.3	10.2	10.2	10.3	10.0	10.3	10.7	11.7	12.2	10.4
Well Average Depth 2020	10.3	10.1	10.0	10.0	10.4	10.2	9.9	10.4	11.3	11.7	12.2	12.4
Well Average Depth 2021	10.5	9.7	9.7	10.0	10.1							

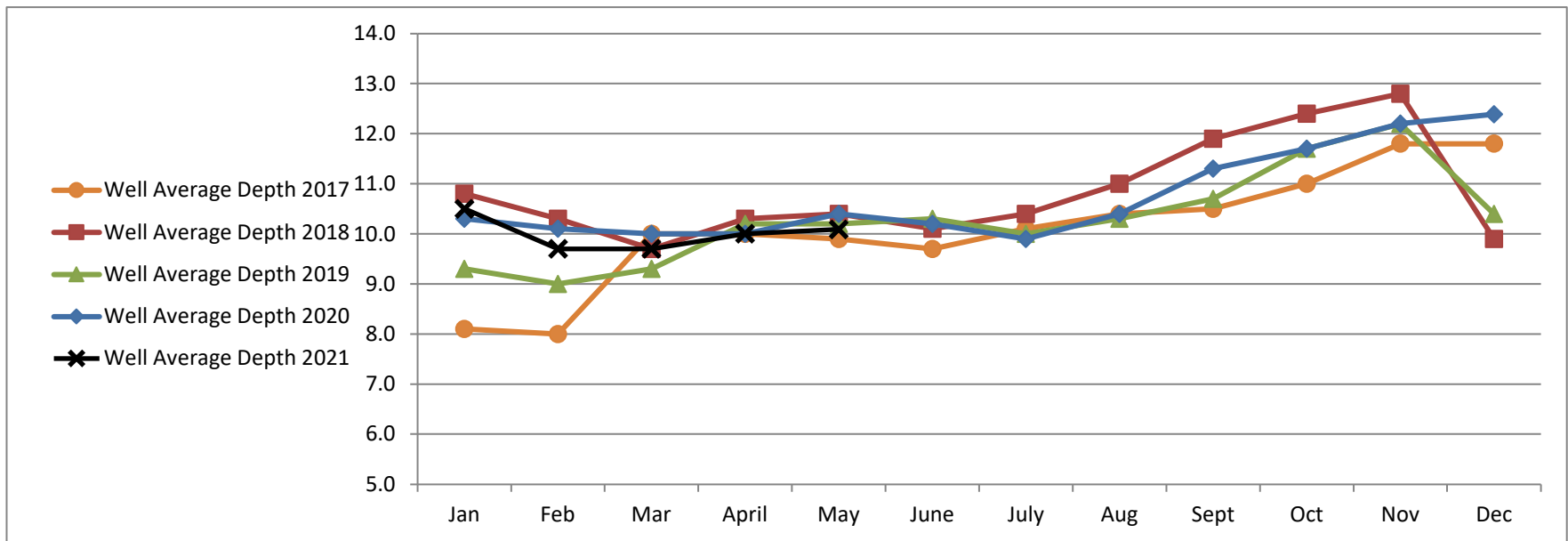

5. A. iii GENERAL MANAGER'S REPORT
Charles Grace
Update for May 2021



GENERAL MANAGER'S REPORT

Item 5.A.iii

Staff Activity – Report on Staff activities for the month of May 2021. Regular activities performed by District staff include:

Processing of utility payments, customer service duties, answering phone calls, mailing of the regular monthly utility bills. Prepared and distributed the agenda and Board packet for both a regular and two (2) special meetings.

Staff also attended to the following items:

- Responded to twelve (12) public records requests. One (1) request is still being assembled.
- Notice was posted in the New Times on May 27 advertising the UWMP / ISFM RFP. Although not legally required, on May 28, 2021 staff mailed the request for proposal (RFP) for the update to the water master plan to 35 firms. The RFP was posted on the district's website on Tuesday June 1, 2021, and although not legally required the notice was sent to several trade journals on June 2.
- Coordinated the June 10, 2021 meeting with San Luis Obispo Grand Jury.

Update on District Grants:

OPC Grant – None

LCP Grant – None

Update on District Projects:

Water Tank Project Update – The existing contract with Phoenix Engineering will expire June 30, 2021. At this time, Phoenix Engineering does not intend to renew the agreement suggesting that the SSCSD contact Phoenix Engineering once the tank project regains a path forward.

Solid Waste Authority – RRM Design has started work on the proposed rules that would be adopted by the District related to Solid Waste Authority. Additionally, staff had a meeting with the Integrated Waste Management Authority (IWMA) related to SB 1383.

5. A. iv. DISTRICT FINANCIALS
Cortney Murguia
May 30, 2021

SAN SIMEON COMMUNITY SERVICES DISTRICT



5.A.iv FINANCIAL SUMMARY

Billing May 31, 2021

April Billing Revenue	\$	90,447.21
May Billing Revenue	\$	75,868.84
Past Due (60+ days)	\$	9,610.47

ENDING BANK BALANCES

May 31, 2021

PACIFIC PREMIER BANK:

Money Market Account Closing Balance April 30, 2021	\$	1,093,919.22
Interest for April	\$	129.19
Money Market Account Closing Balance April 30, 2021	\$	1,094,048.41
Reserve Fund	(250,000.00)	
Wait-list Deposits	(70,836.00)	
Customer Deposits	(8,900.00)	
Available Funds	\$	764,312.41

General Checking Account May 31, 2021 \$ 138,121.38

LAIF Closing Balance May 31, 2021 \$ 560.50

Interest Money Market Account 2019 \$ 22,529.11

Interest Money Market Account 2020 \$ 12,206.44

Interest Money Market Account 2021 \$ 762.89

SAN SIMEON COMMUNITY SERVICES DISTRICT

**Balance Sheet
As of May 31, 2021**

	<u>May 31, 21</u>
ASSETS	
Checking/Savings	
1010 · Petty cash	150.00
1015 · Pac Prem Ckg-6603	128,307.61
1017 · Pacific Premier-Money Market	1,014,175.72
1050 · LAIF - non-restricted cash	<u>560.50</u>
Total Checking/Savings	1,143,193.83
Other Current Assets	
1200 · Accounts receivable	99,096.62
1300 · Prepaid expenses	<u>1,079.90</u>
Total Other Current Assets	<u>100,176.52</u>
Total Current Assets	1,243,370.35
1400 · Fixed assets	
1420 · Building and structures	279,580.67
1500 · Equipment	12,689.93
1560 · Pipe bridge	29,497.00
1580 · Sewer plant	869,343.61
1600 · Water system	235,615.43
1620 · WWTP expansion	299,565.92
1630 · Tertiary Project	568,063.00
1640 · Wellhead Rehab Project	448,253.95
1650 · Walkway access projects	26,791.00
1660 · RO Unit	948,021.38
1680 · Generator	<u>18,291.00</u>
Total 1400 · Fixed assets	3,735,712.89
1450 · Construction in Progress	
1670 · Reservoir / Water Tanks	<u>287,693.56</u>
Total 1450 · Construction in Progress	287,693.56
1690 · Accumulated depreciation	<u>(1,531,591.18)</u>
Total Fixed Assets	<u>2,491,815.27</u>
TOTAL ASSETS	<u><u>3,735,185.62</u></u>

LIABILITIES & EQUITY

Liabilities	
2100 · Payroll liabilities	(30.60)
2500 · Customer security deposits	8,700.00
2510 · Connect hookup wait list	70,944.00
2520 · USDA Loan	442,920.02
Total Liabilities	522,533.42
Equity	
3200 · Fund balance	2,329,133.43
3201 · BOD designated - water improve	53,618.00
3202 · BOD designated-WW improvement	53,315.00
3203 · BOD designated-gen fund improve	15,065.00

SAN SIMEON COMMUNITY SERVICES DISTRICT

**Balance Sheet
As of May 31, 2021**

	<u>May 31, 21</u>
3204 · BOD designated for reserves	250,000.00
3205 · BOD designated for customer dep	80,140.00
3206 · Unrestricted net equity	576,332.00
3900 · Suspense	(89.06)
Net Income	<u>(144,862.17)</u>
Total Equity	<u>3,212,652.20</u>
TOTAL LIABILITIES & EQUITY	<u><u>3,735,185.62</u></u>

DISTRICT REVENUE FY 2020/2021

	Jul-20	Aug	Sep	Oct	Nov	Dec	Jan-21	Feb	Mar	Apr.	May	June	Totals
State Billing			\$4,898.26			\$4,898.26			\$9,978.14				\$19,774.66
Property Tax	\$2,336.92	\$751.11	\$11.88	\$6,945.71	\$5,461.44	\$26,458.17	\$12,827.64	\$1,063.98	\$5,505.65	\$8,582.80	\$15,086.53		\$85,031.83
Water	\$40,209.97	\$54,512.44	\$41,179.63	\$40,129.44	\$30,132.26	\$30,099.00	\$31,207.86	\$28,567.08	\$27,866.11	\$39,907.47	\$31,637.78		\$395,449.04
Sewer	\$45,546.00	\$60,488.59	\$45,320.14	\$44,227.62	\$32,486.93	\$31,269.68	\$29,285.81	\$31,276.88	\$30,546.56	\$44,784.48	\$34,747.31		\$429,980.00
Service	\$7,830.48	\$7,834.18	\$7,910.24	\$7,872.17	\$8,062.36	\$7,948.27	\$7,910.24	\$7,910.24	\$7,834.18	\$7,796.15	\$7,910.24		\$86,818.75
Recycled Water													\$0.00
Late Fees	\$0.00	\$0.00	\$0.00	\$0.00	\$0.00	\$0.00	\$0.00	\$0.00	\$0.00	\$0.00	\$0.00		\$0.00
Grant Funds	\$0.00	\$0.00	\$0.00	\$0.00	\$0.00	\$0.00	\$0.00	\$0.00	\$0.00	\$0.00	\$0.00		\$0.00
Total	\$95,923.37	\$123,586.32	\$99,320.15	\$99,174.94	\$76,142.99	\$100,673.38	\$81,231.55	\$68,818.18	\$81,730.64	\$101,070.90	\$89,381.86		\$1,017,054.28
Water Sold Cu Ft	292033	387244	297886	291236	218802	217498	215864	209660	203888	291683	230285		2856079
Water Sold Acre ft	6.70	8.89	6.84	6.69	5.02	4.99	4.96	4.81	4.68	6.70	5.29		65.57

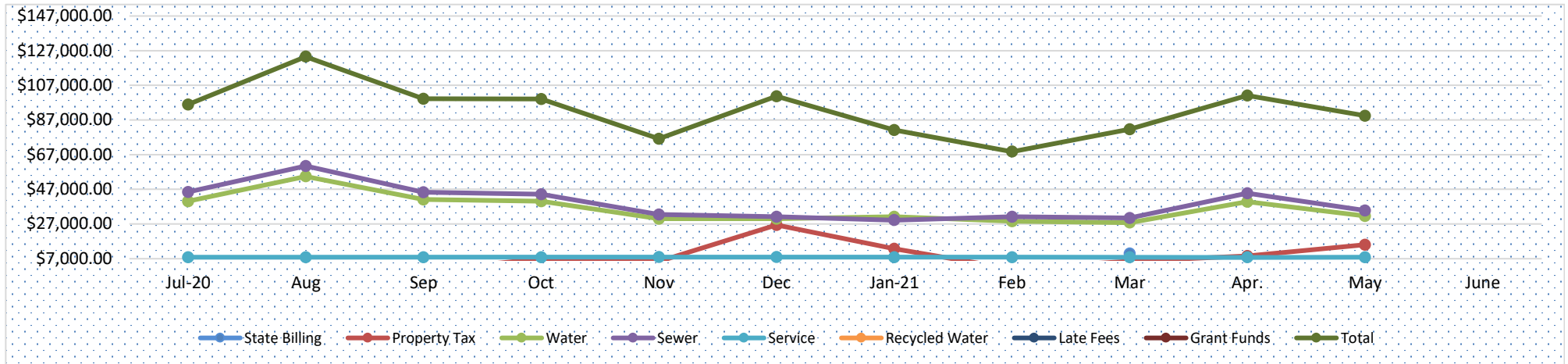

REVENUE VS EXPENSES

	Jul-20	Aug	Sep	Oct	Nov	Dec	Jan-21	Feb	Mar	Apr.	May	June	Totals
Revenue	\$95,923.37	\$123,586.32	\$99,320.15	\$99,174.94	\$76,142.99	\$100,673.38	\$81,231.55	\$68,818.18	\$81,730.64	\$101,070.90	\$89,381.86		\$1,017,054.28
Expenses	\$87,144.37	\$81,902.63	\$114,623.38	\$160,041.02	\$98,357.85	\$137,804.21	\$111,151.88	\$106,602.36	\$84,771.53	\$71,795.69	\$91,754.68		\$1,145,949.60
Balance	\$8,779.00	\$41,683.69	(\$15,303.23)	(\$60,866.08)	(\$22,214.86)	(\$37,130.83)	(\$29,920.33)	(\$37,784.18)	(\$3,040.89)	\$29,275.21	(\$2,372.82)		(\$128,895.32)

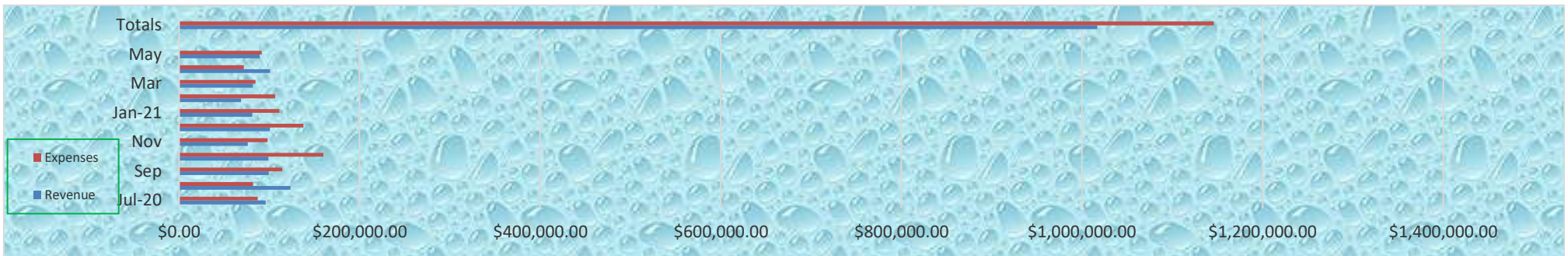

**SAN SIMEON COMMUNITY SERVICES
HISTORICAL FISCAL REVIEW**

FY 2017/2018

Month	Jul	Aug	Sep	Oct	Nov	Dec	Jan	Feb	Mar	Apr	May	Jun	Fiscal Total
State Billing			\$24,606.31			\$21,914.14			\$21,542.66			\$23,690.87	\$91,753.98
Property Tax	\$1,282.43		\$121.78	\$3,983.38	\$11,222.22	\$31,099.09	\$7,506.90	\$2,750.02	\$640.94	\$22,168.20	\$1,686.05	\$771.97	\$83,232.98
Water	\$34,880.43	\$36,192.33	\$31,137.52	\$27,999.25	\$26,930.07	\$19,762.53	\$22,551.64	\$25,457.70	\$16,741.07	\$28,408.76	\$27,795.23	\$36,075.95	\$333,932.48
Sewer	\$38,495.46	\$39,770.86	\$33,836.96	\$30,919.58	\$29,421.68	\$21,164.32	\$25,021.12	\$28,652.26	\$19,108.33	\$32,900.73	\$31,492.38	\$40,773.70	\$371,557.38
Service	\$6,820.12	\$6,950.95	\$6,821.63	\$6,659.98	\$6,886.29	\$6,886.29	\$6,789.30	\$6,853.96	\$6,724.64	\$6,724.64	\$6,724.64	\$6,724.64	\$81,567.08
Late Fees	\$628.24	\$379.06	\$292.61	\$241.85	\$221.14	\$159.01	\$113.69	\$197.92	\$487.09	\$284.43	\$202.63	\$179.47	\$3,387.14
Grant Funds	\$332,310.87						\$42,858.00						
Revenue	\$82,106.68	\$83,293.20	\$96,816.81	\$69,804.04	\$74,681.40	\$100,985.38	\$61,982.65	\$63,911.86	\$65,244.73	\$90,486.76	\$67,900.93	\$108,216.60	\$965,431.04
Expense	\$94,660.34	\$87,503.06	\$104,489.98	\$71,763.52	\$62,490.35	\$85,613.60	\$88,196.48	\$73,251.65	\$109,510.66	\$70,856.21	\$80,363.24	\$80,743.66	\$1,009,442.75
Balance	(\$12,553.66)	(\$4,209.86)	(\$7,673.17)	(\$1,959.48)	\$12,191.05	\$15,371.78	(\$26,213.83)	(\$9,339.79)	(\$44,265.93)	\$19,630.55	(\$12,462.31)	\$27,472.94	(\$44,011.71)
Water Sold Cu Ft	299369	310960	266284	241692	232942	169355	194345	217741	144425	244412	237414	308832	2,867,771
Water Sold Acre f	6.87	7.14	6.11	5.55	5.35	3.89	4.46	5.00	3.32	5.61	5.45	7.09	65.84

FY 2018/2019

Month	Jul	Aug	Sep	Oct	Nov	Dec	Jan	Feb	Mar	Apr	May	Jun	Fiscal Total
State Billing			\$26,723.91			\$20,971.00			\$19,858.71			\$19,390.52	\$86,944.14
Property Tax	\$1,288.59		\$169.19	\$7,205.82	\$8,542.19	\$33,187.58	\$1,319.32	\$4,888.55	\$2,227.01	\$22,928.34	\$3,062.24	\$1,057.02	\$85,875.85
Water	\$41,336.59	\$45,279.14	\$41,178.74	\$34,050.67	\$30,760.16	\$24,353.21	\$29,009.60	\$27,745.06	\$24,146.67	\$35,445.24	\$29,158.01	\$38,455.33	\$400,918.42
Sewer	\$47,258.33	\$53,156.35	\$47,379.43	\$39,628.31	\$35,491.84	\$28,149.21	\$34,169.78	\$32,181.86	\$27,850.19	\$41,666.62	\$33,854.74	\$44,856.07	\$465,642.73
Service	\$7,111.73	\$7,113.60	\$7,113.60	\$7,113.60	\$7,079.40	\$7,079.40	\$7,147.80	\$7,079.40	\$7,079.40	\$7,079.40	\$7,045.20	\$7,079.40	\$85,121.93
Late Fees	\$461.43	\$201.49	\$290.08	\$168.71	\$600.53	\$135.60	\$178.43	\$146.51	\$126.87	\$177.46	\$111.54	\$272.66	\$2,871.31
Grant Funds				\$11,367.00		\$18,753.05							
Revenue	\$97,456.67	\$105,750.58	\$122,854.95	\$88,167.11	\$82,474.12	\$113,876.00	\$71,824.93	\$72,041.38	\$81,288.85	\$107,297.06	\$73,231.73	\$111,111.00	\$1,127,374.38
Expense	\$81,495.91	\$74,250.58	\$102,279.81	\$104,990.12	\$111,554.79	\$92,037.25	\$94,850.91	\$94,625.06	\$71,744.58	\$105,016.25	\$89,244.32	\$98,066.81	\$1,120,156.39
Balance	\$15,960.76	\$31,500.00	\$20,575.14	(\$16,823.01)	(\$29,080.67)	\$21,838.75	(\$23,025.98)	(\$22,583.68)	\$9,544.27	\$2,280.81	(\$16,012.59)	\$13,044.19	\$7,217.99
Water Sold Cu Ft	334631	367360	332914	275609	243491	195107	236456	227602	197397	288979	236030	311046	3,246,622
Water Sold Acre f	7.68	8.43	7.64	6.33	5.59	4.48	5.43	5.23	4.53	6.63	5.42	7.14	74.53

FY 2019/2020

Month	Jul	Aug	Sep	Oct	Nov	Dec	Jan	Feb	Mar	Apr	May	Jun	Fiscal Total
State Billing			\$25,528.71			\$22,455.35			\$15,776.54			\$7,016.19	\$70,776.79
Property Tax	\$1,218.61	\$2,752.21	\$3,126.48	\$5,305.64	\$6,019.52	\$23,503.23	\$13,612.60	\$5,282.91	\$2,659.00	\$15,436.18	\$9,385.45	\$916.22	\$89,218.05
Water	\$41,718.97	\$39,623.52	\$40,324.01	\$43,808.36	\$32,208.00	\$23,432.56	\$33,732.14	\$34,067.23	\$24,268.55	\$17,909.86	\$28,582.31	\$36,460.31	\$396,135.82
Sewer	\$48,137.21	\$45,503.27	\$45,161.69	\$48,244.57	\$34,916.02	\$26,527.95	\$39,321.56	\$39,368.21	\$27,637.52	\$19,243.28	\$29,934.22	\$37,683.06	\$441,678.56
Service	\$7,113.60	\$7,045.20	\$7,079.40	\$7,451.10	\$7,489.26	\$7,344.54	\$7,525.44	\$7,453.08	\$7,489.26	\$7,489.26	\$7,489.26	\$7,453.08	\$88,422.48
Recycled Water													\$0.00
Late Fees	\$1,957.04	\$2,399.24	\$1,407.87	\$468.45	\$316.84	\$1,136.41	\$237.28	\$307.96	\$2,793.44	\$5,540.71	\$4,647.78	\$3,802.45	\$25,015.47
Grant Funds			\$8,750.00	\$167,376.61						\$1,485.90		\$8,369.50	\$185,982.01
Revenue	\$100,145.43	\$97,323.44	\$122,628.16	\$105,278.12	\$80,949.64	\$104,400.04	\$94,429.02	\$86,479.39	\$80,624.31	\$65,619.29	\$80,039.02	\$93,331.31	\$1,111,247.17
Expense	\$90,205.84	\$67,705.50	\$94,401.58	\$97,595.50	\$87,822.01	\$86,173.97	\$85,716.44	\$75,643.11	\$62,582.54	\$73,942.83	\$90,232.61	\$79,762.52	\$991,784.45
Balance	\$9,939.59	\$29,617.94	\$28,226.58	\$7,682.62	(\$6,872.37)	\$18,226.07	\$8,712.58	\$10,836.28	\$18,041.77	(\$8,323.54)	(\$10,193.59)	\$13,568.79	\$119,462.72
Water Sold Cu Ft	336845	319458	323518	329822	242893	179311	260006	261505	185972	137196	217871	274085	3,068,482
Water Sold Acre f	7.73	7.33	7.43	7.57	5.58	4.12	5.97	6.00	4.27	3.15	5.00	6.29	70.44

PAGE INTENTIONALLY LEFT BLANK



ADHOC COMMITTEE REPORTS

List of Committee Members:

- i. **Status Report** – Disbursements Journal Review Committee members:
Director Maurer and Vice-Chairperson Giacoletti.
- ii. **Status Report** – Policy & Procedures Committee members:
Chairperson Kellas and Director Carson.
- iii. **Status Report** – Parking on District Streets Committee members:
Director de la Rosa and Vice-Chairperson Giacoletti.
- iv. **Status Report** – Budget Committee members:
Michael Hanchett, Miguel Sandoval, Luz Hernandez, Director William Maurer
(Committee Chairperson)
- v. **Status Report** – Water Committee members:
John Russell, Leroy Price, Michael Hanchett, Director Daniel de la Rosa

6. CONSENT AGENDA

- A. Review and approval of Minutes for the Regular Meeting on May 13, 2021.**

MINUTES
SAN SIMEON COMMUNITY SERVICES DISTRICT
BOARD OF DIRECTORS REGULAR MEETING
Thursday, May 13, 2021
5:00 pm

Internet Meeting Location – via ZOOM

1. REGULAR SESSION @ 5:05 PM

- A. Chairperson Kellas – Present
- Vice-Chairperson Giacoletti – Present
- Director Carson – Present
- Director Maurer – Present
- Director de la Rosa – Present

2. PUBLIC COMMENT FOR ITEMS NOT ON THE AGENDA:

Public Comment – (4:15)

Julie Tacker commented on the May 6, 2021 letter from SLO County related to the grant inquiries and the Hearst easement matter, the Hurlbert encroachment, complaints from the public that had not been responded too, and public records requests that had not been filled.

Michael Donahue spoke stating that he agreed with Julie Tacker’s comment about the County’s grant inquiry letter needing to be added to the meeting agenda.

Henry Krzciuk commented on May 6th letter from SLO county related to the grant inquiry. He also commented on an alleged Brown Act violation.

Michael Hanchett commented and thanked staff and the Board for their work and dedication. He listed several projects that had been successfully completed by staff.

(16:18) Vice-Chairperson Giacoletti inquired about the lack of a closed session on the meeting agenda, stating that she believed another closed session was supposed to occur.

(18:45) Director Maurer spoke stating that he wanted to speak about the cancellation of the Budget Committee meeting and the inquiry from the County regarding grant monies.

(21:05) Chairperson Kellas followed up on the question from Vice-Chairperson Giacoletti asking District Counsel to clarify if closed session should have occurred.

(23:00) Director Maurer clarified that he thought that no reportable action had been taken during closed session.

3. SPECIAL PRESENTATIONS AND REPORTS:

A. STAFF REPORTS:

- i. **Sheriff's Report** – (24:12) Chris Langton provided the report for the month of April.

(27:55) Michael Hanchett commented and Henry Krzciuk commented.

(31:05) Tina Dickason was allowed to speak because of technical difficulties during the public comment period. She asked about the presence of Greg Sanders during the April closed session.

- ii. **Superintendent's Report** – (31:28) Jerry Copeland provided a summary of April activities.
- iii. **General Manager's Report** – (33:55) Charles Grace provided a summary of April activities.
- iv. **District Financial Summary** – (35:42) Charles Grace provided a summary of April financials.
- v. **District Counsel's Report** – (37:15) Jeffrey Minnery provided a summary of April activities.

A. AD-HOC COMMITTEE REPORT:

- i. **Status Report** – (39:45) Director Maurer provided a summary of what the ad-hoc committee was working on stating that they were continuing to prepare their findings for the Board.

B. PUBLIC COMMENTS ON SPECIAL PRESENTATIONS AND REPORTS:

Public Comment –

(40:10) Henry Krzciuk commented.

(42:45) Julie Tacker commented.

(46:40) Michael Hanchett commented.

(49:40) Director Maurer asked Jeffrey Minnery about the number of public records request and the number of people who were submitting these requests.

4. CONSENT AGENDA ITEMS:

A. Review and approval of Minutes for the Regular Meeting on April 8, 2021.

B. Review and approval of Minutes for the Special Meeting on April 22, 2021.

C. Review and approval of Disbursements Journal.

(53:10) Director Maurer inquired about the Oliveira Environmental Consulting invoice and what agreement was being used to cover the billing costs. He also inquired about the charges for the services provided by Paavo Ogren.

Public Comment –

(57:00) Julie Tacker commented.

(1:00:06) Henry Krzciuk commented.

(1:02:50) A motion was made to approve the consent agenda items A-C.

Motion: Chairperson Kellas

2nd: Director Carson

Vote: 5/0

Abstain:

Roll Call: Kellas: Yes Carson: Yes Maurer: Yes de la Rosa: Yes Giacoletti: Yes

5. BUSINESS ACTION ITEMS:

A. Update and Discussion regarding Paavo Ogren contract related to the moratorium. (1:03:05)

Charles Grace introduced the item.

(1:07:20) Director Carson asked if Paavo Ogren was present. He also asked if Mr. Ogren was absent because he was not interested in the contract being renewed. Jeffrey Minnery provided a response stating that Mr. Ogren had a previous engagement.

(1:08:50) Director Maurer commented that he was having a hard time following the flow chart.

(1:11:20) Chairperson Kellas and Director Maurer discussed the possibility of contacting persons on the waitlist to see if they were still interested in building.

(1:11:52) Vice-Chairperson Giacoletti commented that without the presence of Mr. Ogren to provide an explanation about the handouts, she was also having a hard time following the numerical items on the flow chart. Chairperson Kellas provided an explanation about the steps and how the need for CEQA would or would not impact the flow of the items.

(1:14:52) Director Maurer asked if the original contract funds allotted to Paavo Ogren had been used up. Chairperson Kellas provided an answer stating that they had been used up.

(1:15:30) Director de la Rosa asked if there was any duplication in the work that Paavo Ogren was doing, and if any of this work was being completed by the District's other consultants. Charlie Grace responded that these efforts were not being duplicated.

Public Comment –

(1:18:12) Henry Krzciuk commented.

(1:21:18) Julie Tacker commented.

(1:24:30) David Sansone commented.

(1:27:05) Michael Hanchett commented.

(1:29:00) Director Carson asked Mr. Krzciuk to please email him the notes related to drought calculations. He also stated that it was difficult to make any decision about the renewal of the contract without Mr. Ogren being present at the meeting.

(1:32:05) Director Maurer asked that Mr. Krzciuk please email him the notes related to drought calculations. Director Maurer concurred with Director Carson's comments. Director de la Rosa

spoke and asked if it would be possible to establish a requirement that Mr. Ogren please provide a monthly status report.

(1:33:50) Vice-Chairperson Giacoletti commented that she disagreed with Mr. Krzciuk's comments regarding the order of events related to the issuance of will serve letters.

(1:36:58) Jeffrey Minnery confirmed that he had called Mr. Ogren during the Board's discussion and confirmed that Mr. Ogren wanted to continue working with the District. Chairperson Kellas responded that there were two options on the table related to moving forward with Mr. Ogren. Director Carson proposed the idea of approving another 30 hours of time to allow Mr. Ogren to continue his work.

(1:39:27) Vice-Chairperson Giacoletti suggested that perhaps the item should be tabled until July.

(1:40:45) Director de la Rosa suggested that the District may wish to continuing using Mr. Ogren in an incremental fashion. Director Carson also proposed that the District may wish to find a middle ground that worked for both parties and again suggested allowing for an additional thirty (30) hours. Director Maurer said that he was in-between de la Rosa and Carson and proposed allowing an additional ten (10) hours of time for Mr. Ogren to continue his work. Chairperson Kellas said that \$1,000.00 would allow for 5.5 hours.

(1:45:55) Director Carson made a motion to allow an additional 25 hours of time on Paavo Ogren's contract.

Motion: Director Carson
2nd: Director Maurer
Vote: 3/2
Abstain:

Roll Call: Kellas: Yes Giacoletti: No Carson: Yes Maurer: Yes de la Rosa: No

B. Direction to staff regarding the responses from the request for proposal related to the Coastal Hazard Response Plan (CHRP). (1:50:24)

Charles Grace introduced the item. There was discussion amongst staff about which representatives from Dudek and Hassan were present at the meeting.

(1:54:20) Director Maurer questioned the representatives from Hassan Consultants about what their approach would be related to the requirements from the Coastal Commission regarding the Local Coastal Plan (LCP).

Public Comment –

(1:59:10) Henry Krzciuk commented.

(2:00:58) Julie Tacker commented. (There was a sidebar about conflict of interest with Chairperson Kellas.)

(2:04:52) Michael Hanchett commented.

(2:06:55) David Sansone commented.

(2:08:25) Director Maurer stated the District should move forward with awarding a contract.

(2:09:58) Vice-Chairperson Giacoletti commented that she thought that Hassan was more qualified to perform the work.

(2:10:10) Chairperson Kellas commented that the Hassan was qualified to perform the work and that they were a disadvantaged small business which would fair well on grant applications/awards that the District might apply for.

(2:11:52) Director Carson commented that although both contractors were qualified to perform the work, he believed that Dudek might be better suited to perform the tasks.

(2:13:30) Vice-Chairperson Giacoletti commented that she agreed with Chairperson Kellas's comments and the District should take these comments seriously.

(2:13:50) Chairperson Kellas made a motion to award Hassan Consultants the work.

Motion: Chairperson Kellas
2nd: Vice-Chairperson Giacoletti
Vote: 2/3
Abstain:

Roll Call: Kellas: Yes Giacoletti: Yes Carson: No Maurer: No de la Rosa: No

(2:14:58) Director Carson made a motion to award Dudek the scope of work.

Roll Call: Kellas: No Giacoletti: No Carson: Yes Maurer: Yes de la Rosa: Yes

C. Presentation of the Draft FY 2021/2022 Budget. (2:16:10)

Charlie Grace introduced the item stating that the budget committee meeting had been cancelled.

Public Comment –
(2:17:52) Henry Krzciuk commented.
(2:21:00) Julie Tacker commented.
(2:24:28) Michael Hanchett commented.

There was no action taken on this item.

D. Direction to staff regarding the proposed video contract with Lori Mather Video Services to record regular and special Board meetings. (2:29:15)

Charlie Grace introduced the item.

Public Comment –
(2:30:40) Henry Krzciuk commented.
(2:32:59) Julie Tacker commented.
(2:35:35) Lori Mather commented.
(2:35:57) Cortney Murguia commented.
(2:37:10) Michael Hanchett commented.

(2:39:25) Director Maurer and Jeff Minnery discussed whether the services agreement did suffice as a services agreement.

(2:40:40) Chairperson Kellas made a motion to approve the services agreement with Lori Mather Video Services.

Motion: Chairperson Kellas

2nd: Director Carson

Vote: 5/0

Abstain:

Roll Call: Kellas: Yes Giacoletti: Yes Carson: Yes Maurer: Yes de la Rosa: Yes

E. Discussion related to the formation of an Ad Hoc Committee to update the Policy & Procedures manual. (2:42:11)

Charlie Grace introduced the item.

(2:42:58) Vice-Chairperson Giacoletti asked about the need for a committee because the Board had just received an updated manual. Chairperson Kellas responded by providing background information about the need for updates.

Public Comment –

(2:46:04) Henry Krzciuk commented.

(2:47:14) Julie Tacker commented.

(2:51:15) Chairperson made a motion for an Ad hoc committee consisting of Chairperson Kellas and Director Carson.

Motion: Chairperson Kellas

2nd: Director Carson

Vote: 5/0

Abstain:

Roll Call: Kellas: Yes Giacoletti: Yes Carson: Yes Maurer: Yes de la Rosa: Yes

F. Discussion regarding District Ordinance 107 and draft Ordinance 122 related to parking on District streets. (2:52:20)

Charlie Grace introduced the item.

(2:53:32) There was a conversation between Director de la Rosa, Jeffrey Minnery, and Charles Graces about the term legal summary regarding the Martin versus City of Boise case. There was also discussion with Director Maurer, Director de la Rosa, and Chairperson Maurer about the requirement of parking permits on District streets and potential fire hazards caused by cars that are parked on vacant lots with long grass.

Public Comment –

(3:12:15) Patrick Flaverty commented.

(3:15:34) Director Carson commented that although he was not a big fan of parking permits, he thought they could be mailed out with the water bills. He also advised that the conversation should be kept broad to avoid potential conflict of interest issues with individual Board members.

(3:20:28) Vice-Chairperson Giacoletti volunteered to be the other member of the Ad hoc committee.

The Board also asked that a statement be included in the newsletter asking that residents refrain from parking on vacant lots.

(3:24:39) Director de la Rosa made a motion that Vice-Chairperson be appointed to the Ad hoc committee and that the committee continuing looking at the all the options of parking ordinances and report back to the Board.

Motion: Director de la Rosa
2nd: Chairperson Kellas
Vote: 5/0
Abstain:

Roll Call: Kellas: Yes Giacoletti: Yes Carson: Yes Maurer: Yes de la Rosa: Yes

G. Consideration of endorsing correspondence requesting COVID19 relief funding be allocated to special districts. (3:27:15)

Chairperson Kellas introduced the item.

Public Comment –
(3:30:05) Michael Hanchett commented.

(3:31:00) Chairperson Kellas made a motion to allow for the endorsement of correspondence requesting COVID19 relief funding be allocated to special districts.

Motion: Chairperson Kellas
2nd: Director Carson
Vote: 5/0
Abstain:

Roll Call: Kellas: Yes Giacoletti: Yes Carson: Yes Maurer: Yes de la Rosa: Yes

6. CLOSED SESSION –

A. Public Comment –

(3:32:50) Henry Krzciuk commented.
(3:34:10) Julie Tacker commented.

B. Pursuant to Government Code Section 54956.9 (d)(2) Conference with District Legal Counsel regarding anticipated litigation. Number of cases: one (1) Robert Hather. (3:39:00)

(3:39:20) Reconvene to Open Session – there was no reportable action.

7. BOARD/STAFF GENERAL DISCUSSIONS AND PROPOSED AGENDA ITEMS – Chairperson Kellas asked about changing the budget committee from a standing committee to an Ad hoc committee and discussion about greensheet items.

8. ADJOURNMENT @ 9:36 PM

DRAFT

6. CONSENT AGENDA

B. Review and approval of Minutes for the Special meeting on May 27, 2021.

SPECIAL MEETING MINUTES
San Simeon Community Services
Board of Directors Closed Session Meeting



Internet Meeting Location – via ZOOM

1. OPEN SESSION @ 5:07 PM

- A. Chairperson Kellas – Present
- Vice-Chairperson Giacoletti – Present
- Director Carson – Present
- Director Maurer – Present
- Director de la Rosa – Present

2. BUSINESS ACTION ITEM:

- A. **Approval of contract for legal services for Adamski, Moroski, Madden, Cumberland, and Green, LLC. (3:28)**

Jeffrey Minnery introduced the item.

PUBLIC COMMENT –

(5:03) Henry Krzciuk commented.

(8:35) Julie Tacker commented.

(10:56) Michael Hanchett commented.

(12:06) Director Maurer and Jeffrey Minnery discussed working to reduce the cost of legal bills down for the District.

(13:00) Vice-Chairperson Giacoletti asked about the additional legal costs associated with phone calls.

(13:30) Chairperson Kellas made a motion to table the item to allow for a more thorough review.

(14:00) Director de la Rosa and Director Maurer asked about having a bi-weekly review of the bills and associated costs related to legal services.

(16:55) Director Carson stated that he believed that trying to do a bi-weekly review of the bills might actually incur additional legal costs for the District because this task would require additional efforts.

(18:00) Vice-Chairperson Giacoletti remarked that she was unsure why the District should table the item.

(18:50) Director Carson inquired about a portion of the contract and asked for clarification on the language. Jeffrey Minnery provided a response.

(20:48) Director Carson made a motion to approve the contract for legal services.

Motion: Director Carson

2nd: Director Maurer

Vote: 4/1

Abstain: Kellas

Roll Call: Kellas: abstain Giacoletti: Yes Carson: Yes Maurer: Yes de la Rosa: Yes

3. CLOSED SESSION –

A. Public Comment –

(22:25) Henry Krzciuk commented.

(25:42) Julie Tacker commented.

(26:40) Michael Donahue commented.

B. Pursuant to Government Code Section 54956.9 (d)(2) Conference with District Legal Counsel regarding anticipated litigation. Number of cases: one (1) Robert Hather. (31:40)

4. RECONVENE TO OPEN SESSION –

(32:35) Reconvene to Open Session – there was no reportable action.

5. ADJOURNMENT @ 6:18 pm

6. CONSENT AGENDA

C. Approval of the disbursements journal

SAN SIMEON COMMUNITY SERVICES DISTRICT
Disbursements Journal
 June 2021

<u>Type</u>	<u>Date</u>	<u>Num</u>	<u>Name</u>	<u>Memo</u>	<u>Paid Amount</u>
Payments processed in prior months, not posted to previous Disbursement Journals					
Bill Pmt -Check	04/22/2021	2481	San Simeon Ranch/Hearst Corp	Hearst RO facility encroachment review costs through 2/28/2021. Inv 1005 dated 3/1/2021.	-17,193.15
Check	05/11/2021	2482	Gwen Kellas, Director	Reimb for tuition covered by CSDA scholarship. Per P&P 15.0 Reimbursement	-175.00
Payments processed in June 2021					
Paycheck	06/10/2021	2230	GWEN KELLAS	Board Service May 2 through June 1, 2021.	-92.35
Paycheck	06/10/2021	2231	MARY P GIACOLETTI	Board Service May 2 through June 1, 2021.	-92.35
Paycheck	06/10/2021	2232	WILLIAM E MAURER	Board Service May 2 through June 1, 2021.	-92.35
Paycheck	06/10/2021	2233	WILLIAM J CARSON	Board Service May 2 through June 1, 2021.	-92.35
Bill Pmt -Check	06/10/2021	2234	Adamski Moroski Madden Cumberland & Green	General legal fees including Paavo Ogren services through 04/30/21. Inv 54124 dated 5/31/21.	-6,565.99
Bill Pmt -Check	06/10/2021	2235	California Rural Water Association	Membership dues for July 2021 - June 2022. Invoice due date 06/31/21.	-443.00
Bill Pmt -Check	06/10/2021	2236	CGS Engineering Corp	Replace motor on influent pump #1, with Lahr Electric Motor. Inv 107 dated 5/26/21.	-2,678.93
Bill Pmt -Check	06/10/2021	2237	Kathleen Fry Bookkeeping Services	Bookkeeping services April 2021. Inv CSD-2021-04 dated 4/30/21.	-1,320.00
Bill Pmt -Check	06/10/2021	2238	Lori Mather Video Services	Video services for special meetings on 5/27/21 and 6/4/21.	-600.00
Bill Pmt -Check	06/10/2021	2239	Lori Mather Video Services	Video services for regular board meeting held on 5/13/21.	-300.00
Bill Pmt -Check	06/10/2021	2240	Lori Mather Video Services	Video services for regular board meeting held on 6/10/21.	-300.00
Bill Pmt -Check	06/10/2021	2241	New Times	Public ad for Invitation to Bid for an Update to the SSCSD Master Plan to include a UWMP. Inv ...	-54.00
Bill Pmt -Check	06/10/2021	2242	rrm design group	Solid waste authority planning services, coordinate with LAFCO. Inv 0440-02-0421 dated 5/13/21.	-472.50
Bill Pmt -Check	06/10/2021	2243	Simply Clear Marketing & Media	Monthly Website Service and Mgt fee service period May 21 - June 20, 2021. Inv 31533 dated 5/18/2021.	-400.00
Bill Pmt -Check	06/10/2021	2244	Town and Country Fencing, Inc.	Remove and replace chain link fencing and gate. Inv 2440 dated 5/28/21.	-2,242.00
Bill Pmt -Check	06/10/2021	2245	Grace Environmental Services	Operations Management June 2021. Inv 1455 dated 6/1/21.	-54,197.39
Bill Pmt -Check	06/10/2021	2246	Oliveira Environmental Consulting LLC	Prof Svcs related to CHRP-Coastal hazard response plan and other CSD tasks. 4/30/2021-06/02/2021...	-2,712.50
Check	06/25/2021	Elec Pymt	CalPERS Fiscal Svcs Div	Retiree Health monthly premium.	-351.65
Check	06/25/2021	Elec Pymt	CalPers Fiscal Svcs Divn	Monthly Unfunded Accrued Liability payment. Cust. ID # 7226734344.	-1,317.97
Liability Check	06/25/2021	Elec Pymt	United States Treasury (US Treasury)	Payroll tax payment for paychecks dated 06/10/2021.	-61.20
TOTAL					-91,754.68

7. A. Business Items



BUSINESS ACTION ITEMS STAFF REPORT

Item 7.A. Discussion regarding the FY 2021/2022 Budget.

Summary:

The Budget Committee Chairperson Bill Maurer will provide a summary of the May 27, 2021 budget committee meeting.

7. B. Business Items



BUSINESS ACTION ITEMS STAFF REPORT

Item 7.B. Direction to staff regarding entering into an agreement with Raider Painting to recoat the pipe bridge not to exceed the amount of \$45,000.00.

Summary:

The pipe bridge needs to be recoated.

Section 19.03 of the Policy and Procedures manual requires the following:

B. Solicitation of Three Written Bids or Requests for Proposals for Expenditures Exceeding \$10,000 but Not Exceeding \$50,000

When any expenditure is expected to exceed \$10,000, but not exceed \$50,000, the General Manager, or said designee, shall solicit a minimum of three (3) vendors or contractors to submit written bids or proposals. Written entries documenting that three written proposals were solicited shall be noted by the General Manager in the project file. There may be special circumstances, however, when fewer than three (3) vendors are available to submit a proposal or fewer than three (3) vendors submit proposals. In such cases, the General Manager shall justify the reason(s) three vendors could not be solicited with written documentation retained in the project file.

1. Alternative Selection Procedure for Expenditures Exceeding \$10,000

When the District is seeking a unique solution to a problem or situation that cannot necessarily be resolved by the lowest bidder (i.e. when the methods, approaches, and procedures to be used in performing the work are of primary importance), a "Point Count/High Score" method of selecting a proposal may be utilized. Before soliciting proposals, the District must determine the method of evaluation and include the appropriate information in the request for proposal. If a "Point Count/High Score" method will be used, a comprehensive evaluation plan must be developed and finalized. All rating and scoring factors that are to be considered must be included, criteria for considering costs must be developed, and the evaluation plan must provide for a fair and equitable evaluation of all proposals. Scoring factors must take into consideration cost and that factor cannot be less than 30% of the total points available. Proposals received under this method shall first be evaluated to determine whether they were received in time and in the manner prescribed to determine which ones meet the format requirements specified in the request for proposal. Those proposals that meet the

format requirements shall then be submitted to an evaluation committee which shall be comprised of the General Manager and one Board member. The evaluation committee will evaluate and score the proposals using the methods specified in the request for proposal. The contract must be awarded to the responsible, responsive proposal given the highest score by the evaluation committee.

Note: *Invitation for Bids* are typically used to obtain simple, common, or routine services that may require personal or mechanical skills (i.e. little discretion is used in performing the work). *Requests for Proposals* are used to obtain complex services in which professional expertise is needed and may vary. *Requests for Proposals that will utilize the alternative selection procedure* should be used only to obtain very complex and/or unique services in which professional expertise and methods vary greatly or creative/innovative approaches are needed. (i.e. public relations, advertising, complex research projects).

Recommendation:

Staff contacted four vendors, three of which chose to provide quotes. Attached are the estimates from the four vendors. Staff requests approval for the Raider Painting quote not to exceed the amount of \$45,000.00.

Enc: Copy of Quotes from:
Raider Painting in the amount of \$ 41,500.00.
Trombley Painting Company in the amount of \$42,470.00.
Intext Coatings, Inc. in the amount of \$52,254.00.

Raider Painting Quote



JOB: SAN SIMEON PIPE BRIDGE | 9245 BALBOA AVENUE, SAN SIMEON CA 93452

To: Charles Grace / Grace Environmental Services
2060D Avenida De Los Arboles, Thousand Oaks, CA 91362

cgrace@graceenviro.com
805-431-6253

Bid submitted by: Brandon – Phone: 619-495-0318 or Email: brandon@raiderpainting.com

Painting:

PRICE: \$ 41,500

- Protection: Includes laying plastic under work areas in water runoff creek – encapsulation not included. Rider will minimize the footprint of the project by avoiding access creek access as much as possible any by protecting areas of the creek under work being completed. Vegetation trimming may occur as needed to clear small branches that overhang the bridge but will be done to the minimum extent possible. Spraying work will not be conducted when there is high wind.
- Plastic will be laid in the work area to capture material stripped/removed from the pipe bridge, and for capturing paint/coatings that may spill during application.
- Coating Scope: SSPC SP2/3 Hand and Power Tool preparation standards to all accessible areas.
- Coating: Spot prime with rust inhibiting primer, apply full coat of high solids, aluminum filled, polyamine bisphenol epoxy (SW Epoxy Mastic Aluminum II) and top-coat with UV stable coating – 1 color.

Extra Work / Time & Material Rates: SLO-2021-1 Industrial Painter – Repaint rate of \$54.17/hr.

Materials: Cost+20% Standard Rate: \$125/hour Prevailing Wage Rate Included: Yes
Overtime and Weekends: 1.5X Standard Rate (2X for Sunday/Holiday) Specialty work billed at higher rates.

Client’s Initial: _____

5/27/2021 – Valid 30 Days

Page 1 of 4



JOB: SAN SIMEON PIPE BRIDGE | 9245 BALBOA AVENUE, SAN SIMEON CA 93452

CLARIFICATIONS & EXCLUSIONS

Clarifications

1. Colors to match existing or be selected by client. Includes one color only for all areas.
2. Restroom facilities, parking, and storage areas to be supplied by client.
3. Work to be completed from ladders and lifts.
4. Substrate inconsistencies will be visible through the final coat depending on their severity. Due to existing substrates Raider cannot guaranty a smooth and consistent finish on all substrates.
5. Pricing reflects work during normal business hours: Monday through Friday between 7am – 3pm. Overtime and Saturday work charged at 1.5x standard rate. Sundays and holidays at 2.0x.
6. Extra work is billed at \$125/man-hour and materials plus 20%. Specialty work billed at higher rates.
7. Travel costs for any return trips will be charges as a CO including travel pay and per diam.
8. Work to be performed on continues basis without interruptions. Extra mobilizations will result in CO.
9. Client is responsible for informing others of work being performed, notifications & permitting (if required). RPC will not be responsible for loss of revenue to businesses from lack of access.
10. Raider will not provide security. Area may be closed during work and cure period.
11. If retention is agreed to, it must be paid 30 days after OUR work is completed. Bonding not included.
12. In the event of accidental spillage will; contain spillage by creating berm around spill, remove spill and any small amount of soil that may be affected, and bag spoils and dispose of according waste material regulations. Any such events will be reported to client (SCSD at 805-927-4778).

Exclusions

1. Intumescent, elastomeric, monokote, anti-graffiti, block sealer, specialty coatings not noted in scope.
2. Artist work, faux, wood grain matching, patina, stenciling, decals, metal etching, special finishes.
3. Permitting. Price does not include special containment, scaffold, or creek protection beyond plastic.
4. Asbestos and lead testing or abatement. Client certifies work areas are lead & asbestos free. Dust containment. Water containment/reclamation – water will be left to dry in place. SWPP Plans. Fees, fines, legal actions or damage associated with these items are solely client's responsibility.
5. Union membership or PLA execution. RPC is open shop & non-union.

Client's Initial: _____

5/27/2021 – Valid 30 Days

Page 2 of 4



PO Box 2898 | Merced, CA 95344

714-377-1427, fax: 714-377-9818

JOB: SAN SIMEON PIPE BRIDGE | 9245 BALBOA AVENUE, SAN SIMEON CA 93452

CONTRACT ACCEPTANCE AND SIGNATURE PAGE

This proposal MUST be included as an addendum to the client’s contract or purchase order and/or the entirety of this proposal MUST be integrated into client’s contract.

Please initial each page (including T&C’s), sign below & return ALL pages of proposal.

Total Contract Amount (Includes selected ALTS): _____

Payment Terms: NET 30

Company Name

Type (LLC, Corp., Sole Prop. Etc.)

Name of signer

Title

Signature

Date

Representation on Authority of Parties/Signatories:

Each person signing this Agreement represents and warrants that he or she is duly authorized and has the legal capacity to execute and deliver this Agreement. Each party represents and warrants to the other that the execution and delivery of the Agreement and the performance of such party's obligations hereunder have been duly authorized and that the Agreement is a valid and legal agreement binding on such party and enforceable in accordance with its terms.

**THE ATTACHED TERMS AND CONDITIONS ARE AN INTEGRAL PART OF THIS AGREEMENT AND ARE HEREBY INCORPORATED.
CLIENT MUST INITIAL EACH PAGE OF THE T&C’S AND RETURN WITH THE SIGNED PROPOSAL.**

Client’s Initial: _____

5/27/2021 – Valid 30 Days

Page 3 of 4



JOB: SAN SIMEON PIPE BRIDGE | 9245 BALBOA AVENUE, SAN SIMEON CA 93452

RAIDER PAINTING COMPANY TERMS & CONDITIONS:

ALL APPLY UNLESS OTHERWISE SPECIFIED IN PROPOSAL:

STANDARD EXCLUSIONS: Protection of work following completion, repairs to damages by others, protection/moving of personal property, stand-by time for work not ready, overtime, permitting, night work. Return mobilizations due to trade damage, unfinished work or uninstalled items will result in CO. Final coat will not be installed following all other work unless specifically noted above. Window washing – following painting it is recommended that client arrange for window washing work. Call-Offs and return visits due to unprepared work and damage will be charged at standard T&M with a minimum 8 hr per worker called off. Materials included are commercial grade industry standard. Overtime.

Artist work, faux, wood grain matching, patina, stenciling, decals, metal etching, deck coatings, intumescent, elastomeric, monokote, anti-graffiti, block sealer, specialty finishes/coatings or any other special finishes.

Work within 10' of active power lines unless client arranges for utility to safe off. For stage/scaffold work: Tieback Certification and engineering certification.

Prevailing wage rates and certified payroll. Union membership or PLA execution – Raider Painting is open shop. If PW rate is noted above request for CPR must be completed in writing prior to work commencement. CPR for work before request will not be available.

ABATMENT & CONTAINMENT: Asbestos and lead testing are excluded. Client certifies work areas are lead and asbestos free. Abatement or disposal of hazardous materials is excluded. Dust containment is excluded. Water containment and reclamation is excluded– water will be left to dry in place and storm drains blocked as not to allow run-off. SWPP Plans not included. Fees, fines, legal actions or damage associated with these items are solely client's responsibility.

DECK COATING/WATERPROOFING: Excludes floor sloping, drain installation, moisture testing, moisture barrier, cracking, delamination, or failures caused by hydrostatic pressure or moisture entry at slab on grade conditions, acts of nature, fire, settling, or movement of substrate. Mitigation of specific water entry – we cannot guarantee that the above application will curtail all water infiltration being experienced without performing flood testing to eliminate all potential sources. Deck coatings without texture or aggregate may be slippery when wet – slip co-efficient or certification not included. Color may vary from samples.

TRADE DAMAGE: Return mobilizations due to trade damage, unfinished work or uninstalled items, will result in additional job site visit costs. Wall finish acceptance for Level 3-5 is to be by others prior to RPC mobilization. Call-Offs and return visits due to unprepared work and damage will be charged at standard T&M rates as specified in attached proposal. Lost days will be billed at full rate of eight hours per called off man plus travel, if applicable.

WALL ACCEPTANCE: Client is responsible for final wall acceptance prior to application of paint. Final wall acceptance should be by whomever will punch final work. Wall finish acceptance for Level 3-5 is to be by others prior to RPC mobilization. Return trips or punch work due to unsatisfactory wall finish will be charged as a CO. If Raider is also contracted to compete wall finish, then finish acceptance and repairs are included.

RESTRICTED ACCESS & SECURITY CLEARANCE: Entrance & exit through security or restriction of any kind is not included. Delays beyond 5 minutes for entry/exit will be billed at applicable T&M rates.

INSPECTION & TESTING EXCLUSION: Delays impeding the continuous performance of our work due to client or owner required inspections and/or testing of our work, or the surrounding immediate area, that causes delays to Raider crews in any way are not included unless noted in scope. Delays will be charged at applicable T&M rates. Raider reserves the right to stop work until change order is executed for such delays and testing.

MEDICAL CLEARANCE, SAFETY TRAINING & JOBSITE CLASSES: RPC will conduct bi-weekly Toolbox Safety meetings per OSHA requirements. Any further mandated classes or trainings required for clearance or access to the job site will be charged at T&M rates.

CHANGE ORDER POLICY: No change order work will be performed without a written and signed approval on client's company letterhead indicating a change in the total contract amount. **NO VERBAL OR EMAIL APPROVALS will be accepted.**

INSURANCE INCLUDED IN BID: Commercial General Liability: Each Occurrence-\$1,000,000; General Aggregate - \$2,000,000; Blanket Waiver of Subrogation or Additional Insured by written request only. *Specifically named waivers of subrogation for General Liability are not available. *Named Additional Insured endorsements can be supplied at \$516 per endorsement per entity will be billed separately. RPC will supply CG 20 10 04 13 and CG 20 37 04 13 endorsements. **Excess Umbrella: \$4,000,000**

Business Auto: Single Limit - \$1,000,000

Worker's Compensation: Each Occurrence - \$1,000,000;

*Waiver of subrogation by written request ONLY.

Evidence of insurance coverage provided upon request.

Named certificates issued ONLY upon receipt of signed contract or Notice to Proceed. Raider will not provide XCU coverage, as this is not applicable to our trade.

PAYMENTS TERMS: DUE UPON RECEIPT: Work will be billed upon completion with "Due upon receipt" terms, unless otherwise specified above. Net 30 terms are available for pre-qualified customers only and require prior authorization. Credit card payments add additional 3% to total contract value.

NON PAYMENT/COLLECTIONS: Invoices unpaid after 30 days will be sent to collections. Collections costs (30% of past due balance) and/or attorney's fees will be the client's (the undersigned's) sole responsibility. An additional 1% interest per month, 12% per annum, will be charged from the due date of the invoice(s). Any collection, attorney fees and/or interest charges are in addition to past due invoice amount.

Lien Releases: Pursuant to California Civil Code Section 3262 (d) (1-4). Raider Painting Company will provide a "Conditional Waiver and Release" for progress and/or final payments, per California Lien Waiver Laws. Once said payment has been received, properly endorsed and paid by the bank upon which it is drawn, Raider Painting Company will then fax and mail to the payee an original notarized "Unconditional Waiver and Release", upon client's request. If client requires waivers, or other documentation, returned by overnight courier, client must provide Raider Painting their preferred courier account number. **No overnight courier fees are included in this bid proposal. We will not exchange Unconditional waivers for checks. No Exceptions.**

ATTENTION GENERAL CONTRACTORS:

-Refer to Lien Waiver section.

-No pick-up of checks at jobsites.

-Retention payment must be within maximum of 90 days of completion of our work. We will not agree to wait until GC finishes its work under the prime contract to receive retention.

-Any legal venue MUST be in city/county & state where project is located.

NOTICE: "Under the Mechanics Lien Law, any contractor, subcontractor, laborer or other person who helps to improve your property but not paid for his work or supplies, has a right to enforce a claim against your property. This means that after a court hearing your property could be sold by a court officer and the proceeds of the sale used to satisfy the indebtedness. This can happen even if you have paid your own contract in full, if the subcontractor, laborer, or supplier remains unpaid"

Client's Initial: _____

5/27/2021 – Valid 30 Days

Page 4 of 4

Trombley Painting Company Quote

CA Small Business
Lic. 1059270
EMR Rate – .85
DART RATE – 0
I&I Rate – 0
DIR - 1000016401



716 Paso Robles Street
Paso Robles, CA 93446
Office: (805) 296-3124
FAX: (805) 237-1781

Proposal

Customer: Charles Grace
Grace Environmental Service
cgrace@graceenviro.com

#20-099

May 14, 2021

Project: Grace Environmental Service
Pipe Bridge
9245 Balboa, San Simeon, CA

Balboa Street Pipe Bridge

General Scope of Work to be performed for Grace Environmental Services (the "Customer") as Follows:

The following is based upon San Luis Obispo Prevailing Wage Determination 2021-2.

- Set up of Scaffolding and Break Down will be provided by Rolls Scaffold prior to any preparation and finishing to be started, as set forth in Exhibit A. Grace Environmental Service is hereby deemed the Customer for purposes of Exhibit A.
- Minimize the footprint of the project by avoiding access to the creek to the maximum extent possible by using scaffolding and ladders for access. Scaffolding shall bridge span of creek and keep men out of the plants, mud and rocks etc, as well as on the two sides to access the upper Frame and Pipes adequately. Followed by immediate tear down upon completion of project.
- Protection, such as containment equipment, shall be placed so that stripped material such as rust, paint chips, paint, etc. shall be collected as work progresses. Containment equipment will remain in place to collect any material during the paint application process.
- Vegetation removal will not be allowed or performed except to the extent removal of small branches which overhang the bridge is necessary to complete the project.
- Pipes and Framework shall receive a thorough Hand Clean including removal of all dirt, grease, oil, salt and chemical contaminants. Mold and Mildew shall be removed with a chlorinated cleaner ad rinsed thoroughly with fresh water.
- Surfaces shall be sanded, scraped, of all loose rust or paints, solvent cleaned, followed by a spot rust converter prior to primer coat.
- Two coats Rust- Oleum NOXYDE shall be applied at a minimum of 7 mils per coat.
- Two Coats of Rust-Oleum Metal Max DTM Acrylic Enamel Top-Coat shall be applied at a minimum of 5-7 mils per coat.

CA Small Business
Lic. 1059270
EMR Rate – .85
DART RATE – 0
I&I Rate – 0
DIR - 1000016401



716 Paso Robles Street
Paso Robles, CA 93446
Office: (805) 296-3124
FAX: (805) 237-1781

- To the extent possible, removal of existing paint and application of new paint will not be performed during high wind events.
- In the event of an accidental spillage the following steps will be taken:
 1. Contact the SSCSD at (805) 927-4778;
 2. Contain spillage by berming around spill;
 3. Remove spill and any small amount of soil that may be affected; and
 4. Bag and dispose of soils in accordance with applicable waste disposal regulations, Trombley Painting is not responsible any applicable waste disposal fees that might be accrued.
- SSCSD will be contacted immediately in the event of any changes to the proposal or spillage.

Includes Supervision, Labor, Materials and Equipment

PAINTING LABOR AND MATERIALS: \$30,740.00

SCAFFOLD RENTAL: \$12,000.00

GRAND TOTAL: \$42,740.00

Trombley Painting is not responsible for any overtime charged in connection with the work performed by Rolls Scaffold.

Exclusions: No other surfaces other than those at Pipe Bridge is included.

- Includes enough men to complete the project in reasonable time
- Bid good for 30 days
- Water and utilities supplied by owner/prime contractor
- Assumes painting areas to be free and clear of any bushes, trees, obstructions, and debris
- Assumes paint can be sprayed, brushed and rolled
- Assumes non-interference by other trades

This proposal is limited to the scope of work outlined in this document. Anything beyond the scope of work contained in this document, or not explicitly mentioned, is not included in this proposed price.

WE PROPOSE hereby to furnish material and labor-complete in accordance with these specifications, for the sum of: **Prices listed above.** All material is guaranteed to be as specified. All work to be completed in a workmanship like manner according to standard practices. Any alteration or deviation from above specifications involving extra cost will be executed only upon written orders and will become a Change Order over and above the estimate. All agreements

CA Small Business
Lic. 1059270
EMR Rate – .85
DART RATE – 0
I&I Rate – 0
DIR - 1000016401



716 Paso Robles Street
Paso Robles, CA 93446
Office: (805) 296-3124
FAX: (805) 237-1781

contingent upon strikes, accidents or delays beyond our control. Owner/Customer to carry fire, and all other necessary insurance. Trombley Painting is not liable for any environmental impact

caused, created, or otherwise related to the use of scaffolding to complete the project. Further, Trombley Painting is not liable for the payment of any fines, fees, penalties, or damages related to the use of scaffolding to complete the project. The Owner/Customer agrees to indemnify and defend Trombley Painting in the event of any such claims. Payment not to exceed 30 days from billing submission. Includes one mobilization and de-mobilization. More mobilizations will be an extra charge. Delays not caused by Trombley Painting will be charged an extra 4 hour minimum at \$135.00 per hour per man. Does not include lead abatement.

Trombley Painting Representative

Date

CUSTOMER ACCEPTANCE OF PROPOSAL-The prices, specifications and conditions are satisfactory and are hereby accepted. Payment will be made as outlined above.

Customer Representative Signature

Date

Customer Representative Printed Name

CA Small Business
Lic. 1059270
EMR Rate – .85
DART RATE – 0
I&I Rate – 0
DIR - 1000016401



716 Paso Robles Street
Paso Robles, CA 93446
Office: (805) 296-3124
FAX: (805) 237-1781

EXHIBIT A

CA Small Business
Lic. 1059270
EMR Rate – .85
DART RATE – 0
I&I Rate – 0
DIR - 1000016401



716 Paso Robles Street
Paso Robles, CA 93446
Office: (805) 296-3124
FAX: (805) 237-1781

Proposal

Atten: Charles Grace
Grace Environmental Service
cgrace@graceenviro.com

#20-099

May 14, 2021

Project: Grace Environmental Service
Pipe Bridge
9245 Balboa, San Simeon, CA

Balboa Street Pipe Bridge

General Scope of Work to be performed as Follows:

The following is based upon San Luis Obispo Prevailing Wage Determination 2021-2

- Set up of Scaffolding and Break Down will be provided by Rolls Scaffold prior to any preparation and finishing to be started. Scaffolding shall bridge span of creek and keep men out of the plants, mud and rocks etc, as well as on the two sides to access the upper Frame and Pipes adequately. Protection shall be placed so that all rust, paint chips, paint, etc. shall be collected as work progresses. Followed by immediate tear down upon completion of project.
- Pipes and Framework shall receive a thorough Hand Clean including removal of all dirt, grease, oil, salt and chemical contaminants. Mold and Mildew shall be removed with a chlorinated cleaner ad rinsed thoroughly with fresh water.
- Surfaces shall be sanded, scraped, of all loose rust or paints, solvent cleaned, followed by a spot rust converter prior to primer coat.
- Two coats Rust- Oleum NOXYDE shall be applied at a minimum of 7 mils per coat.
- Two Coats of Rust-Oleum Metal Max DTM Acrylic Enamel Top-Coat shall be applied at a minimum of 5-7 mils per coat.

Includes Supervision, Labor, Materials and Equipment

GRAND TOTAL LABOR AND MATERIALS: \$30,740.00

Exclusions: Scaffolding is not included in price and will be billed separately.

No other surfaces other than those at Pipe Bridge is included.

- Includes enough men to complete the project in reasonable time
- Bid good for 30 days
- Water and utilities supplied by owner/prime contractor
- Assumes painting areas to be free and clear of any bushes, trees, obstructions, and debris
- Assumes paint can be sprayed, brushed and rolled

CA Small Business
Lic. 1059270
EMR Rate – .85
DART RATE – 0
I&I Rate – 0
DIR - 1000016401



716 Paso Robles Street
Paso Robles, CA 93446
Office: (805) 296-3124
FAX: (805) 237-1781

- Assumes non-interference by other trades

This proposal is limited to the scope of work outlined in this document. Anything beyond the scope of work contained in this document, or not explicitly mentioned, is not included in this proposed price.

WE PROPOSE hereby to furnish material and labor-complete in accordance with these specifications, for the sum of: **Prices listed above.** All material is guaranteed to be as specified. All work to be completed in a workmanship like manner according to standard practices. Any alteration or deviation from above specifications involving extra cost will be executed only upon written orders, and will become a Change Order over and above the estimate. All agreements contingent upon strikes, accidents or delays beyond our control. Owner to carry fire, and all other necessary insurance. Payment not to exceed 30 days from billing submission. Includes one mobilization and de-mobilization. More mobilizations will be an extra charge. Delays not caused by Trombley Painting will be charged an extra 4 hour minimum at \$135.00 per hour per man. Does not include lead abatement.

Trombley Painting Representative

Date

CUSTOMER ACCEPTANCE OF PROPOSAL-The prices, specifications and conditions are satisfactory and are hereby accepted. Payment will be made as outlined above.

Customer Representative Signature

Date

Customer Representative Printed Name



PROPOSAL AGREEMENT

05/17/2021

Trombley Painting
 Attn: Tamara
 Email: tamara@trombleypainting.com

Project: 9245 Balboa Ave
 San Simeon

Rolls Scaffold, Inc. ("ROLLS") provides, and the parties herein enter into, the following Proposal Agreement ("Agreement") related to the above referenced project ("Project") for the above referenced customer ("Customer").

NOTICE: This Agreement is a binding contract between ROLLS and Customer and Customer's signature evidences their approval and agreement to all terms and conditions contained in this Agreement. ROLLS is under no obligation to lease any equipment and materials to Customer or perform any work related to the Project unless and until this Agreement is executed by Customer.

After this Agreement, Invoices will be issued to Customer related to the Work and/or Project. Any such invoices shall be deemed incorporated into and made a part of this Agreement.

If ROLLS is required to sign a separate subcontract agreement related to the Project, this Agreement remains binding between the parties and shall be deemed fully incorporated into any such subcontract agreement. To the extent any terms and conditions of such subcontract agreement contradicts with any terms and conditions of this Agreement, this Agreement's terms and conditions shall supersede and be controlling between the parties.

1. ROLLS SCOPE OF WORK

ROLLS will provide the following scope of work ("Work") for the Project for the following rates:

ITEM 1: Provide systems scaffold for approximately 63' lineal feet with a max height of 6'. Scaffold will be erected under piping for paint work and be free standing. Scaffold will be built for light duty work (25psf) and span over creek area. The scaffold structure to have top planked level doubled guard rail with access provided to all planked levels of scaffold. Rolls will need written approval before erecting scaffold in creek area.

LUMP SUM PRICE ITEM 1: \$12,000.00

PRO-RATED AFTER INITIAL 28-DAY RENTAL PERIOD: \$120.00 per day thereafter

The "Lump Sum" pricing includes delivery, erection, initial rental period, dismantling and removal of scaffold material. Any scaffold provided by ROLLS shall meet or exceed CAL OSHA regulations.

2. PRICING CONDITIONS & ADDITIONAL COSTS

- a. **Rental Term, Payment Terms & Late Payments:** The initial term of this Agreement commences upon every delivery of the scaffolding or equipment, or any part thereof, to the Project address. Customer agrees to pay the initial term of the rental period and further agrees to pay for each continuation period hereafter all rental charges, which shall be due and owing for each date up to and including the date the scaffolding and equipment is provided back to ROLLS. All initial charges and

11351 County Drive, Ste. B
 Ventura, Ca 93004
 CA 915580

P.O. Box 7909
 Ventura, Ca 93006
 DIR 1000023637

Phone: (805) 988-8825
 Toll Free: (800) 523-4775
 Fax: (805) 988-9947

Initial: _____



- tax is due when this Agreement is signed. Payment of continuation rental charges are due on the commencement of each continuation term. All payments shall be made to ROLLS at its address. If any payments owed ROLLS are not paid on or before thirty (30) days from the applicable invoice date, Customer shall pay to ROLLS interest on the overdue payment from the date such payment was due to the date of actual payment at a rate of 1.5% per month, or if lower, the maximum amount permitted under Law.
- b. **Transportation Charges.** Customer agrees to pay ROLLS its usual service charges for “curbside” transportation to or from the lessee’s jobsite or yard. Time spent by Rolls’ driver locating equipment, loading, etc., will be charged at Rolls’ then current hourly rate.
 - c. **Price Revisions & Deadline:** The Price quoted Customer in this Agreement is based on information supplied by Customer, or upon conditions existing at time of job walk. As job-sites vary, price is subject to revision pending actual commencement of scaffold erection. Price is subject to change if Agreement is not accepted within 60 days of quote or if the Customer has changed the scope of work in any way.
 - d. **Normal Work Hours & Non-Union Wage:** Unless otherwise indicated in this Agreement, all Work shall be performed during normal, straight-time working hours (7:00am to 3:30pm), during a normal workweek (Monday through Friday) Any additional work required or requested by Customer outside of normal working hours will be on a time and materials basis of \$75/hour per man plus any incurred costs (“T&M”). **The price in this Agreement is based on prevailing wages.** ROLLS is not a signatory to any Union contract and will not sign any Union contract to initiate or continue any work.
 - e. **Replacement/Repair Costs:** Customer is responsible for any costs associated with the replacement or repair of any scaffolding and equipment that may be lost or damaged prior to ROLLS collecting its equipment from the Project. If ROLLS determines that any scaffold or equipment is lost, stolen, destroyed or damaged beyond repair, Customer shall pay ROLLS all of the following: (1) all amounts then owed by Customer to ROLLS under this Agreement; and (2) the fair market value of said item(s) on the date of such loss, theft, damage or destruction. Customer will be charged the replacement price of the scaffolding and equipment and/or the time required to make any repairs to the scaffolding and equipment. ROLLS has the sole discretion regarding whether to replace or repair any scaffolding or equipment.
 - f. **Dismantle & Removal Costs:** ROLLS will dismantle and remove the scaffold material at one time. Any direction by Customer to remove partial sections will be viewed as an extra to this Agreement and Customer will be billed on a T&M basis. Customer must remove all trash, tools, items, materials, debris, dirt, mud and sand (collectively “Debris”) from the scaffold before ROLLS will dismantle and remove the scaffold. If ROLLS arrives on Project to dismantle and remove scaffold and finds (in its sole discretion) that Customer failed to remove Debris from the scaffold, ROLLS will refuse to dismantle and remove any scaffold and Customer will pay ROLLS a trip charge.
 - g. **Tarps:** Unless identified in the Scope of Work, no tarps will be provided by ROLLS for the Project.
 - h. **Toe Board Costs:** Unless identified in the Scope of Work, ROLLS will only provide toe boards to meet CAL OSHA requirements. Any request by Customer for additional toe boards in excess of CAL OSHA requirements will be at an additional cost to Customer.
 - i. **Credit Card Payments:** If Customer wishes to make payments by credit card, Customer will be required to complete a credit application and a credit card payment authorization agreement. In the event Customer uses credit card payments, ROLLS obligation to provide any services or equipment under the Scope of Work of this Agreement is contingent upon the following: (1) Customer completing the credit application and authorization agreement; and (2) approval of Customer’s credit by ROLLS.
 - j. **Invoices:** Any changes, reductions, or additions to the Scope of Work (including pricing) detailed in any invoices issued by ROLLS after this Agreement will act as an agreed to modification to the Scope of Work between the Parties. Customer also specifically agrees they will be responsible for any and all future/additional rental monthly charges contained in later invoices.



3. **CUSTOMER RESPONSIBILITIES**

- a. **No Ongoing Inspections By ROLLS:** Unless specified in the Scope of Work, ROLLS will not return to inspect the erected scaffold on the Project, and will not perform, nor be obligated to perform, any ongoing inspections of the scaffold. Customer understands and agrees it is responsible for all inspections, maintenance, and upkeep of the scaffold after it is erected on the Project by ROLLS.
- b. **Facilities:** Customer will provide toilet and wash facilities for ROLLS' employees during erection, modification and dismantle of scaffold.
- c. **Competent Inspection & Usage:** Customer understands, agrees, and expressly warrants the following:
 - i. **When Scaffold Erected by ROLLS:** After ROLLS' erects the scaffolding, it is the responsibility of Customer to: (1) only permit properly trained scaffold users to access the scaffolding; and (2) have a "competent person" under the applicable occupational safety and health laws inspect and sign-off on the scaffold being safe to use before allowing any access for users to the scaffolding for each work shift. Customer further agrees it is their responsibility to ensure that all representatives, agents, subcontractors, and all other scaffold users abide by all laws and regulations relating to the proper inspection and use of the scaffolding. Customer understands that the scaffolding will be under their care and control until it is released for dismantle and removal to ROLLS. Customer shall: (1) use any scaffold and equipment in a safe and proper manner; (2) comply with all applicable Federal and State laws, ordinances, rules, regulations and orders of any public authority, including but not limited to all Federal Occupational Safety and Health Act and State regulations, having jurisdiction for the safety of persons or property regarding the use of the scaffold and equipment; and (3) comply with any rules promulgated by ROLLS with respect to the scaffold and equipment and its manner of use. Upon ROLLS completing the installation and erection of the scaffold, Customer shall have twenty-four (24) hours to give notice to ROLLS of any defect in, or other objection to, the scaffolding. In the event no notice is given by Customer within twenty-four (24) hours, it shall be deemed that Customer: (1) fully inspected the scaffolding and found no defects in, or issues with, the scaffolding; and (2) has fully accepted the scaffolding.
 - ii. **When Scaffold Rented to & Erected by Customer:** It is the responsibility of Customer to: (1) erect, use, move, and disassemble the scaffolding only under the direction of a competent person under the applicable occupational safety and health law; and (2) follow any and all applicable Federal and State occupational safety and health laws, rules, regulations, and ordinances in addition to any applicable city, county, or local codes and rules with regard to the use of the scaffold and the inspection of the scaffold and a "competent person" under those rules. Customer further agrees it is their responsibility to ensure that all representatives, agents, subcontractors, and all other scaffold users abide by all laws and regulations relating to the proper inspection and use of the scaffolding. Customer understands that the scaffolding will be under their care and control until it is released for dismantle and removal to ROLLS. Customer shall inspect: (1) all leased scaffold and equipment upon receipt from ROLLS; (2) all leased scaffold and equipment at Project prior to any use by Customer and its employees or any representatives, agents, subcontractors or other scaffold users; and (3) on a continuing basis all leased scaffold and equipment at all times throughout the rental term. Upon receipt of the scaffolding and equipment from ROLLS, Customer shall have twenty-four (24) hours to give written notice to ROLLS specifying any defect in, or other objection to, the scaffold and equipment. In the event no notice is given by Customer within twenty-four (24) hours, it shall be deemed the scaffold and equipment is in good condition and Customer shall be deemed to have fully accepted said scaffold and equipment.



- d. **Controlling Employer**: Customer acknowledges that Customer, and not ROLLS, is the “Controlling Employer” of any users of the scaffold while it is on the Project and, therefore, Customer has the authority and responsibility for the safety of its employees, subcontractors and material men, as well as the safety of other subcontractors, visitors and the owner(s) at the Project. Customer acknowledges and agrees to comply with all statutes and regulations that establish safety requirements including, but not limited to, those of OSHA or CAL OSHA, the EPA, and any local, state, and federal governmental agency regulating job-site safety.
- e. **Training**: Customer is responsible for providing any and all required training to its employees and any other users of scaffold and equipment regarding the safe and proper use of the scaffolding and equipment. Customer represents that all of their employees on any Project are appropriately trained in the relevant safety methods, including those of OSHA or CAL OSHA, the EPA, and any local, state, and federal governmental agency regulating job-site safety.
- f. **Electrical Hazards**: According to federal and state occupational safety and health laws, Customer is responsible for ensuring that all mechanical equipment, electrical circuits, or vessels containing chemicals or pressurized fluids which are located in the immediate vicinity of ROLLS’ Work area are de-energized or rendered inoperative prior to the Work, and that proper tags and/or locks are attached to all points where such equipment can be energized. ROLLS will only erect scaffolding outside of minimum required safe allowable distance from any electrical hazard. Prior to ROLLS erecting any scaffold, it is Customer’s responsibility to arrange with proper utility authority for all necessary safeguards that may be required. If ROLLS determines any electrical hazard is to be shielded or disconnected, the times of power “cut-off” will be provided to ROLLS in writing prior the commencement of any Work by ROLLS.
- g. **Permits**: Customer is responsible for obtaining any and all necessary permits, including street use permits, public use permits, sidewalk permits, noise permits, night work permits, and all other permits issued by any governmental agency necessary and/or required for the Project. Please notify ROLLS if any of the ROLLS’ employees will be working in a confined space and inform ROLLS whether the confined space is permit-required.
- h. **Surface Preparation/Protection**: ROLLS does not offer site preparation services. Customer is responsible for protecting any finished surfaces as they see fit prior to ROLLS arriving to perform the Work and ROLLS is not responsible for any damage that may result to any property as a result of Customer’s choice of preparation/protection. If the scaffold design requires tying or anchoring to a building or other structure it will be the responsibility of the Customer to patch any of the ties/anchor holes.
- i. **No Modifications/Alterations**: Customer understands and agrees the scaffold is not be modified or altered after it is erected by ROLLS on the Project and it is only to be used for the purpose for which it was designed. Any modification or alteration, in whole or in part, of the scaffolding or equipment by the Customer or any contractors or subcontractors using the scaffold on the Project, is done solely at the Customer’s risk and without ROLLS’ authority or approval.
- j. **Tarps**: If Work includes tarping over scaffold structure, Customer agrees to maintain all tarping after ROLLS’ installation; including but not limited to, rolling up tarps and securing to scaffold structure in periods of certain weather conditions (such as high winds and storms). Customer is responsible for any damage (including to the scaffold structure itself) that is caused by failing to maintain or secure tarps.
- k. **Access**: Customer is to ensure reasonable access is provided to ROLLS during the erection and dismantle phases of the Work for material and manpower access to the Project; including but not limited to, building, facility, truck bays, street level, street side, dock areas, elevators, stairways, and entranceways.
- l. **Accident Reporting**: Customer agrees to notify ROLLS immediately of any accident involving the scaffold and equipment that results in injury, death or property damage. Customer understands that time is of the essence after an accident to promptly investigate, and agrees to save and/or record any



www.rollsscaffold.com

- relevant physical evidence (including the taking of photographs and other measures to prevent the spoliation of physical evidence) and the failure to do so is a breach of this Agreement.
- m. **Damaged, Lost or Stolen Equipment:** Customer shall bear the risk of, and be responsible to ROLLS for, any loss, theft, damage, or destruction of the scaffold and equipment from any cause whatsoever. In the event of damage, loss, theft, or destruction of the scaffold and equipment from cause whatsoever, Customer shall notify ROLLS in writing within ten (10) days after discovery. ROLLS shall have the exclusive right to reclaim any scaffold and equipment involved in any such disappearance, theft, or damage to property and to replace the same with comparable scaffold or equipment.
 - n. **Safety Equipment:** Customer must provide their own safety equipment to their employees and/or any contractors, subcontractors or users of the scaffold and equipment. Customer understands and agrees that ROLLS does not rent safety equipment of any type, including, but not limited to nets and safety cables and personal fall protection systems such as lanyards, belts, vests, ropes and grabs.
 - o. **Insurance:** Customer shall keep the scaffold and equipment insured against all risks of loss or damage from every cause whatsoever for not less than the full replacement value thereof naming ROLLS as the additional insured, and shall carry comprehensive public liability and property damage insurance with contractual liability naming ROLLS as an additional insured.
 - p. **Hazardous Substances/Contaminated Equipment:** If any scaffolding or equipment is exposed to any asbestos, mold, materials containing lead, radiation, toxic or hazardous substances, or any other materials that may reasonably represent a hazard to human health, or would preclude or limit future use of the scaffold and equipment by ROLLS (collectively "Hazardous Substances"), Customer shall fully clean and decontaminate, in a manner satisfactory to ROLLS, any and all scaffold and equipment exposed to Hazardous Substances before ROLLS is scheduled to dismantle, modify or remove the scaffolding or equipment. Before ROLLS will dismantle, modify or remove the scaffolding and equipment, Customer must certify in writing to ROLLS that scaffolding and equipment is clean and free of Hazardous Substances. Any rental costs will continue until Customer provides the required certification to ROLLS.
 - q. **Goodwill:** Customer agrees they shall not make any statements and/or do any act that reflect adversely upon and/or damages the brand and goodwill of ROLLS, and Customer shall not exploit or interfere with, or detract from, the public image of ROLLS. Customer further agrees that they shall not make any statements and/or do any act that disparages or reflects negatively upon ROLLS during the term of this Agreement and in perpetuity thereafter.

4. **CUSTOMER INDEMNITY OBLIGATIONS & WAIVER OF LIABILITY**

- a. **Indemnification & Defense:** To the fullest extent permitted by law, Customer and its successors and approved assignees, immediately upon demand by ROLLS, shall at all times protect, defend, indemnify and hold harmless ROLLS, and its owners, managers, officers, directors, employees, representatives, and agents (collectively referred to as "Indemnitees"), from any and all allegations, obligations, liens, demands, claims, liabilities, losses, expenses, lawsuits, actions, damages (including direct, incidental and consequential), liquidated damages, mechanic's liens, costs, attorney's fees (including all attorney's fees and costs to enforce this indemnification provision) with counsel of Indemnitees' choosing, court costs and expenses, bodily injuries (including wrongful death), property damage, and causes of action whatsoever (hereinafter referred to collectively as "Claims") in any way connected with, incidental to, or arising out of (or claimed and/or alleged to arise out of) in whole or in part the following: (i) any act or omission of Customer (and its employees, sub-subcontractors, suppliers or anyone directly or indirectly employed and/or connected by them) on the Project; (ii) Customer's (and its employees, sub-subcontractors, suppliers or anyone directly or indirectly employed and/or connected by them) work on the Project, including, but not limited to, personal and bodily injuries or death, emotional injury, sickness or disease sustained by and/or to any person or property damage of any kind at the Project; (iii) the failure, or alleged failure, of Customer to establish

11351 County Drive, Ste. B
Ventura, Ca 93004
CA 915580

P.O. Box 7909
Ventura, Ca 93006
DIR 1000023637

Phone: (805) 988-8825
Toll Free: (800) 523-4775
Fax: (805) 988-9947

Initial: _____



www.rollsscaffold.com

- and monitor compliance with safety procedures or any violation or infraction of any safety, employment or other governmental law, regulation, or order, including inspections of the scaffolding by a competent person and training of users of the scaffold; (iv) alleged defects in and/or damages to the Project (including loss of use thereof), and/or property appurtenant thereto; (v) defects in Customer's (or any subcontractors or agents of Customer) materials or workmanship; (vi) any failure by Customer to appropriately train or equip its employees in the safety methods relevant to any work on the Project, including those of OSHA, the EPA, and any local, state, and federal governmental agency regulating job-site safety; (vii) Customer's violation of any local, state, or federal law; (viii) any modification or alteration of the scaffold by anyone other than ROLLS; (ix) use of the scaffold and equipment leased to Customer by Customer or any other subcontractors, trades or users of the scaffolding; (x) failure of users on the scaffold to use safety equipment, including but not limited to personal fall protection; (xi) any additional labor costs or penalties assessed by the Project owner and or public agency related to any prevailing wage or Project labor requirements; (xii) damage caused by Customer's choice of site preparation or protection; (xiii) failure to properly secure tarps on the Project; (xiv) exposure or contamination of the scaffold and equipment to Hazardous Substances; and (xv) any breach of this Agreement and any related obligations therein.
- b. Customer's defense and indemnity obligations apply regardless of any passive negligent act or omission of Indemnitees, but customer shall not be obligated to indemnify any Claims arising from: the sole negligence, active negligence or willful misconduct of Indemnitees; or defects in design furnished by Indemnitees.
 - c. The defense and indemnity obligations of Customer contained herein are intended to apply immediately upon demand by Indemnitee and Customer shall immediately assume the defense of the demanding Indemnitee and defend Indemnitee at Customer's expense with counsel of Indemnitee's choosing.
 - d. The defense and indemnity obligations of Customer herein shall not be limited in any way by any insurance or additional insurance requirements, any limitation on the amount or type of damages, compensation or benefits payable under any Worker's Compensation acts, disability benefit or other employee benefit laws, or any other provision of this Agreement. Customer's defense and indemnity obligations apply irrespective of any insurance or additional insurance provided the Indemnitee by Customer.
 - e. Customer's defense and indemnity obligations are intended to apply during the period of this Agreement, and also during, and shall also survive the expiration or termination of the Agreement.
 - f. **Waiver:** Customer releases, waives and discharges any and all allegations, obligations, liens, demands, claims, liabilities, losses, expenses, lawsuits, actions, damages (including direct, incidental and consequential), liquidated damages, mechanic's liens, costs, attorney's fees, court costs and expenses, bodily injuries (including wrongful death), property damage, and causes of action whatsoever against ROLLS related to any of the following: (i) damage to tile or any other types of roofing should ROLLS be required to set scaffolding on a roof top or use a roof top as a means of access; (ii) the need for ROLLS to cut back or remove landscaping to properly install the scaffold; and (iii) damage that may result to any property as a result of Customer's choice of preparation/protection.
5. **OTHER GENERAL CONDITIONS**
- a. **Dissatisfaction with Leased Equipment:** To the extent this Agreement includes Customer leasing scaffold and equipment from ROLLS, if the leased equipment is, or becomes, defective or until because of an accident, obsolescence, or any other cause whatsoever, or the Customer desires to cease the use of the leased equipment for any reason whatsoever, Customer's sole right and remedy shall be the return of the leased equipment to ROLLS and the termination of this Agreement. In the event that

11351 County Drive, Ste. B
Ventura, Ca 93004
CA 915580

P.O. Box 7909
Ventura, Ca 93006
DIR 1000023637

Phone: (805) 988-8825
Toll Free: (800) 523-4775
Fax: (805) 988-9947

Initial: _____



- the equipment is returned, all rental charges incurred are immediately due and the charges in no event shall be less than the transportation costs and the minimum rental as provided.
- b. **Surrender:** Upon termination of this Agreement, Customer shall return the equipment in good repair, ordinary wear and tear resulting from proper use thereof alone expected, by holding it packed and ready for shipment, at such place as ROLLS may specify. Equipment shall not be considered returned until loaded on such truck or vehicle as is provided by ROLLS, unless otherwise agreed by ROLLS in writing. Customer agrees to make himself or his agent available for supervising surrender of equipment and signing off on receipt for returned equipment.
 - c. **Default:** Customer shall be in default under this Agreement if any of the following occurs: (1) Customer fails to pay ROLLS for any amount within ten days after same is due; (2) Customer becomes insolvent or any proceeding in bankruptcy or receivership is commenced; (3) a termination or liquidation of Customer's business occur; or (4) customer is in breach of any terms or conditions of this Agreement. In the event of any default by Customer, ROLLS shall have the right to stop its Work on the Project, terminate any rented equipment and remove any equipment, terminate this Agreement, or seek any other remedy available to ROLLS in law or equity. Customer shall bear all costs and/or expenses (including reasonable attorneys' fees) incurred by ROLLS as a result of Customer's default. ROLLS shall further have the right, but shall not be obligated to exercise any one or more of the following remedies: (1) to sue for and recover all rents and other amounts then due or thereafter accruing under this Agreement; (2) to take possession of any or all of the scaffolding and equipment, wherever it may be located, without demand or notice, without any court or other process of law, and without incurring any liability to Customer, for any damages occasioned by such taking of possession; (3) to terminate this Agreement as to any or all items of equipment; (4) to pursue any other remedy now or hereafter existing at law or in equity. Customer hereby consents to ROLLS entry upon land in possession of Customer to take possession of any item of equipment referred to herein. Notwithstanding any such action that ROLLS may take including taking possession of any or all of the equipment, the Customer shall remain liable for the full performance of all its obligations in this Agreement, provided, however, that if ROLLS in writing terminates this lease as to any item of equipment, ROLLS shall not be liable for rent in respect of such item accruing after the date of such taking of possession. In addition to the foregoing, Customer shall pay ROLLS all costs and expenses, collection costs, including reasonable attorney's fees, incurred by ROLLS in exercising any of its rights or remedies hereunder to enforce the terms of this Agreement.
 - d. **Disclaimer of Warranties:** ROLLS makes no warranty hereunder and all warranties whether expressed, implied or statutory, such as warranties of merchantability or fitness for a particular purpose, are hereby excluded and disclaimed.
 - e. **Entire Agreement:** With the exception of any later invoices issued by ROLLS as referenced in section 2(j), this Agreement embodies the entire agreement of the parties. It may not be modified or terminated except as provided herein or by other written agreement of the parties. However, the parties agree any invoices issued by ROLLS related to this Project and/or Work will act as binding addendums to the Scope of Work of this Agreement without limiting any of ROLLS' respective rights under this Agreement.
 - f. **Choice of Law, Venue & Jurisdiction:** This Agreement shall be governed by and construed in all respects in accordance with the laws of the State of California, without regard to any choice of law principles. The Parties submit to the exclusive jurisdiction of the courts of competent jurisdiction in Ventura County, California. Any dispute arising out of this Agreement or any litigation commenced between the Parties arising out of this Agreement shall proceed in the Superior Court of California, County of Ventura.
 - g. **Attorney Fees & Costs:** In the event of any litigation or proceeding between the parties regarding a dispute arising out of or related to this Agreement, or to enforce any provisions of this Agreement including the enforcement of payment, the prevailing party shall be entitled to recovery from the other party its actual attorneys' fees and costs as may be reasonably incurred, including the cost of



www.rollsscaffold.com

- reasonable investigation, preparation and professional or expert consultation incurred by reason of the litigation and any appeal.
- h. **Interruption of Work:** If, as a result of fire, earthquake, act of God, war, strikes, picketing, boycott, lockouts or other causes or conditions beyond the control of ROLLS, ROLLS discontinues the Work prior to its completion, then ROLLS shall resume Work as soon as conditions permit, and Customer shall not be entitled to any damages or compensation on account of cessation of Work as a result of any of the causes mentioned herein.
 - i. **Captions:** Paragraphs, titles or captions contained in this Agreement are inserted as a matter of convenience and for reference and in no way define, limit, extend or describe the scope of this Agreement or any of its provisions.
 - j. **Consents and Waiver:** No delay by ROLLS in exercising any right under, or in taking any action to enforce any right under, this Agreement will operate as a waiver of any such right or in any manner affect the rights of ROLLS thereunder. No consent by ROLLS under this Agreement or waiver by ROLLS of any representation, warranty, or other term or condition of this Agreement will be effective unless made in writing. Any such waiver will not be construed as a waiver of any other representation, warranty, or other term and condition of this Agreement. Failure by ROLLS to insist upon strict conformity with or strict conformity of, any representation, warranty, or other term or condition in this Agreement in any one or more instances will not be a waiver by ROLLS of its or her right to insist and enforce thereafter strict conformity with, and strict conformity of: (1) such representation, warranty, or other term or condition; or (2) any other representation, warranty, or other term or condition in this Agreement.
 - k. **Counterparts:** This Agreement may be executed in two or more counterparts and copies of each signed counterpart when together shall constitute and be deemed an original, and the same instrument.
 - l. **Severability:** In the event any condition or covenant in this Agreement is held to be invalid or void by any court of competent jurisdiction, the same shall be deemed severable from the remainder of this Agreement and shall in no way affect any other covenant or condition herein contained. If such condition, covenant, or any other provision shall be deemed invalid due to its scope or breadth, such provision shall be deemed valid to the extent of the scope or breadth permitted by law.

Below signee is an authorized representative and agent of Customer with express authority and power to sign for, and enter into this Agreement on behalf of, Customer and bind Customer to this Agreement.

I, CUSTOMER, AGREE TO ALL TERMS AND CONDITIONS STATED IN THIS AGREEMENT

Date: _____ P.O. # _____ Title: _____

Signature: _____ Print: _____

11351 County Drive, Ste. B
Ventura, Ca 93004
CA 915580

P.O. Box 7909
Ventura, Ca 93006
DIR 1000023637

Phone: (805) 988-8825
Toll Free: (800) 523-4775
Fax: (805) 988-9947

Intext Coatings, Inc. Quote



COATINGS, Inc.

Infrastructure Restoration and Preservation

Quote provided exclusively for:

We are pleased to provide you with the following estimate

To:

Charles Grace\
Grace Environmental
cgrace@graceenviro.com

Scope: Protect creek bed with plastic. Prep metal by SP2 and SP3. Spot prime and apply epoxy primer and urethane finish in one color. Includes Prevailing Wages

Total Price:

\$52,254.00

Note:

The project cost is based upon the assumption that the project start date (once agreed upon) will be adhered to and that once work commences it will be allowed to continue un-interrupted until project completion. Standby/downtime time is billed at prevailing wage per man/per hour wherein a delay is encountered as no fault of ENECON NorCal, LLC. INTEXT

INTEXT

COATINGS, Inc.

Infrastructure Restoration and Preservation

Coatings, Inc., or its subcontractors. The referenced quotation is based IN-TEXT Coatings working Monday thru Friday.

Any alteration or deviation from above quotation / specification involving extra cost will be executed only upon written orders, and will become an extra charge over and above the estimate.

Customer shall consult with product manufacturer cure time charts prior to returning equipment to service.

This proposal is valid for 30 (thirty) days

INTEXT Coatings, Inc. is not responsible for structural integrity.

INSURANCE included in this bid as follows: Named certificates issued upon receipt of signed contract or Notice to Proceed. Evidence of insurance provided upon request. Waiver of subrogation not included.

Payment Terms: Final Payment: upon completion

Please mail all payments to:

7641 Ward LN, Fair Oaks, CA 95628
INTEXT COATINGS, INC. 480 334 2542
troy.intextcoatings@gmail.com

Non Payment/Collections:

Invoices unpaid after 30 days will be sent to collections. Collections costs (30% of past due balance) and/or attorney's fees will be the clients (the undersigned's) sole responsibility. An additional 1% interest per month. interest charges are in addition to past due invoice amount.

If you require your own contract in lieu of signing the bid, our proposal MUST be

included as an addendum to contract OR all of the above needs to be integrated into your contract.



COATINGS, Inc.

Infrastructure Restoration and Preservation

Please initial each page, sign below and return ALL pages of this proposal.

Customer Acceptance:

Customer Name:
(Print name):

Acceptance:
(Sign)

Signature of Owner/Officer/Authorized Party/Agent

7. C. Business Items



BUSINESS ACTION ITEMS STAFF REPORT

Item 7.C. Direction to staff regarding entering into an agreement with RNM Engineering, Inc. for construction services management not to exceed the amount of \$9,000.00.

Summary:

RNM Engineering, Inc. was selected to design the water treatment facility distribution pump generator and subsequently the replacement generator for the well pumps. The design also includes powering enough power for future tank lighting and supervisory control data and acquisition (SCADA) backup power. The attached proposal includes design for a generator to power the wells and the entire water treatment facility, cost estimating, assistance with a RFP scope of work, construction management, Section 19.00 of the Policy and Procedures manual requires the following:

2. Selection Procedures for Professional Services in Excess of \$50,000

When the cost for professional services is expected to be in excess of \$50,000, the District shall prepare a Request for Proposal (RFP) which should request the professional's qualifications, relevant experience, described approach, staffing, and support. The proposal should outline the terms, conditions, and specifications of the services required by the District. District staff will review the proposals received, rank the consultants based upon the following criteria, and invite the most qualified firms for interviews:

- a. ability of the consultants to perform the specific tasks outlined in the RFP,
- b. qualifications of the specific individuals who will work on the project,
- c. quantity and quality of time key personnel will be involved in their respective portions of the project,
- d. reasonableness of the fee requested to do the work; comparability of fee to similar services offered by other qualified consultants (except where fee is to be negotiated later),
- e. demonstrated record of success by the consultant on work previously performed for the District or for other public agencies or enterprises,
- f. the specific method and techniques to be employed by the consultant on the project or problem,
- g. ability of the consultant to provide appropriate insurance in adequate amounts, including errors and omissions if applicable, and
- h. responsiveness to the RFP.

The report to the Board shall summarize the basis for staff's consultant selection recommendation and the ranking of the consultants based upon these criteria.

Following Board approval, the General Manager and one Board member shall then execute the contract.

4. Selection Procedures for Professional Services in Excess of \$5,000 Not Exceeding \$10,000

Formal RFP's are not required for professional services in excess of \$5,000 and not exceeding \$10,000. District staff may select a consultant from a pre-qualified consultant file if available. District staff shall contact at least three (3) qualified consultants and request an informal written proposal or verbal proposal. There may be special circumstances, however, when fewer than three (3) vendors are available to submit a proposal or fewer than three (3) vendors submit proposals. In such cases, the General Manager shall justify the reason(s) three vendors could not be solicited with written documentation retained in the project file.

The selection shall be based upon the criteria noted in Section 2 above. Notations documenting the proposals and reasons for selection shall be made in the project file. Following Board approval, the General Manager shall then execute the agreement.

8. Special Circumstances

These professional consultant selection procedures are not applicable when three (3) qualified professional service firms or individuals are unavailable or if it is appropriate and in the best interest of the District under the specific circumstances of the project at issue to limit the number of consultants solicited. Examples of such specific circumstances may include the following: the need to take immediate action on a project precludes the District's ability to follow these procedures; the absence of any fiscal or competitive advantage in following these procedures; only one consultant is known to be available and capable of providing needed services within the required time; the services to be provided are so unique that only one known consultant is qualified and available to perform them; or the terms of a legal mandate or negotiated agreement require the use of a particular consultant. The basis for such action shall be documented in writing and noted in the contract and approved by the General Manager. When Board approval is required, the documented basis for such action shall be included in the report to the Board.

The Board has the following choices:

- 1) The Board may wish to direct staff to move forward with RNM Engineering based on their past performance and familiarity with the existing system.
- 2) The Board can direct staff to obtain additional quotes from engineering firms.

Staff is looking for direction from the Board.

Enc: Copy of quote from RNM Engineering, Inc.

5/20/2021

Charles Grace
GRACE ENVIRONMENTAL SERVICES
2060D Avenida De Los Arboles
Thousand Oaks, CA 91362

Re: San Simeon CSD - RO Backup Generator, Construction Services

Please accept our proposal to furnish Electrical Engineering and Construction Services for the SSCSD Backup Generator Project in San Simeon, CA. Our bid is line-itemed per the scope outlined below:

SCOPE:

1. Review and provide comment on RFP Documentation
COST: \$900
2. Provide Engineering Construction Admin/Services, (20) Hours and (2) Site Visits.
Hours would be billed as used, not to exceed:
COST: \$3,200
3. Provide Alternate Backup Generator Design at increased capacity for total load at RO building. Deliverables: Electrical Construction Drawings (Siteplan, Single Line, Details) and Generator Loading Analysis/Calculations.
COST: \$3,600
4. Provide Engineer's Opinion of Probable Construction Cost of 80kW Generator Design.
COST: \$600
5. Provide Engineer's Opinion of Probable Construction Cost of increased capacity Generator Design per Item #3 above.
COST: \$600

Should you have any questions, please feel free to call us at (805) 234-5277.

Respectfully,

C Stephens
Chris Stephens, PE
RNM Engineering, Inc.

NEW GENERATOR

SAN SIMEON CSD - WATER TREATMENT FACILITY

SAN SIMEON, CA

ELECTRICAL ENGINEER
RNM Engineering, Inc.
 PO BOX 3343
 SAN LUIS OBISPO, CA 93403
 (805) 550-6175
 chris.stephens@RNM-eng.com



NEW GENERATOR
SAN SIMEON CSD - WATER TREATMENT FACILITY
 SAN SIMEON, CA

Date	03/15/2021
Drawn By	CS
Checked By	RNM
Project No.	
Date	Issue
06/08/2020	CUSTOMER REVIEW
01/08/2021	CUSTOMER REVIEW
03/15/2021	100% SUBMITTAL

TITLE SHEET AND GENERAL PLAN

SCALE: AS NOTED

E1

PROJECT DESCRIPTION

THIS PROJECT CONSISTS OF REPLACING AN EXISTING DIESEL GENERATOR WITH A NEW 50KW DIESEL TYPE. A NEW FEEDER, DISTRIBUTION, AND KIRK KEY INTERLOCK SYSTEM WILL ALSO BE INSTALLED FOR PROVIDING MANUALLY OPERATED GENERATOR BACKUP TO THE CIP SKID.

GENERAL NOTES

1. THE ELECTRICAL CONTRACTOR SHALL VERIFY ALL EXISTING CONDITIONS AND SHALL NOTIFY ENGINEER OF ANY DISCREPANCIES WITH CONTRACT DOCUMENTS BEFORE COMMENCING ANY WORK.
2. ALL WORK, LABOR AND MATERIALS SHALL BE PERFORMED IN STRICT COMPLIANCE WITH THE 2019 CALIFORNIA ELECTRIC CODE.
3. THE ELECTRICAL CONTRACTOR SHALL BE RESPONSIBLE FOR CONFORMITY TO ALL LOCAL CODES AND ORDINANCES, THE STATE OF CALIFORNIA ELECTRICAL SAFETY CODES, THE NATIONAL ELECTRIC CODE AND ANY ADDITIONAL JURISDICTIONS RELATING TO THEIR WORK.
4. ALL CONDUCTORS SHALL BE COPPER UL LISTED THWN-2 UNLESS NOTED OTHERWISE.
5. ALL ELECTRICAL EQUIPMENT AND ALL MATERIAL SHALL BE NRTL (NATIONAL RECOGNIZED TESTING LABORATORY), NEMA AND UL RATED.
6. ALL CIRCUIT BREAKERS SHALL BE RATED FOR 75°C TEMPERATURE CONDUCTORS.
7. IN THE EVENT OF A CONFLICT OR INCONSISTENCY BETWEEN ITEMS INDICATED ON THE PLANS AND/OR SPECIFICATIONS OR WITH CODE REQUIREMENTS, THE NOTE, SPECIFICATION OR CODE WHICH PRESCRIBES AND ESTABLISHES THE MORE COMPLETE JOB OR THE HIGHER STANDARD SHALL PREVAIL.
8. THE CONTRACTOR IS RESPONSIBLE FOR DETAILS, PART NUMBER VERIFICATIONS AND ACCURACY FOR CONFIRMING AND CORRELATING ALL QUANTITIES AND DIMENSIONS FOR SELECTING FABRICATION PROCESSES, FOR TECHNIQUES OF ASSEMBLY AND FOR PERFORMING WORK IN A SAFE MANNER.
9. PROVIDE MINIMUM 42" WORK CLEARANCE IN FRONT OF ELECTRICAL EQUIPMENT. PROVIDE A MINIMUM 30" WIDE WORK SPACE IN FRONT OF ELECTRICAL EQUIPMENT.
10. EXCEPT WHERE NOTED OTHERWISE, ALL ABOVE GRADE CONDUIT SHALL BE RIGID METALLIC, ALL BELOW GRADE CONDUIT SHALL BE PVC SCH40



REGIONAL MAP

SCALE: NTS

1
E1

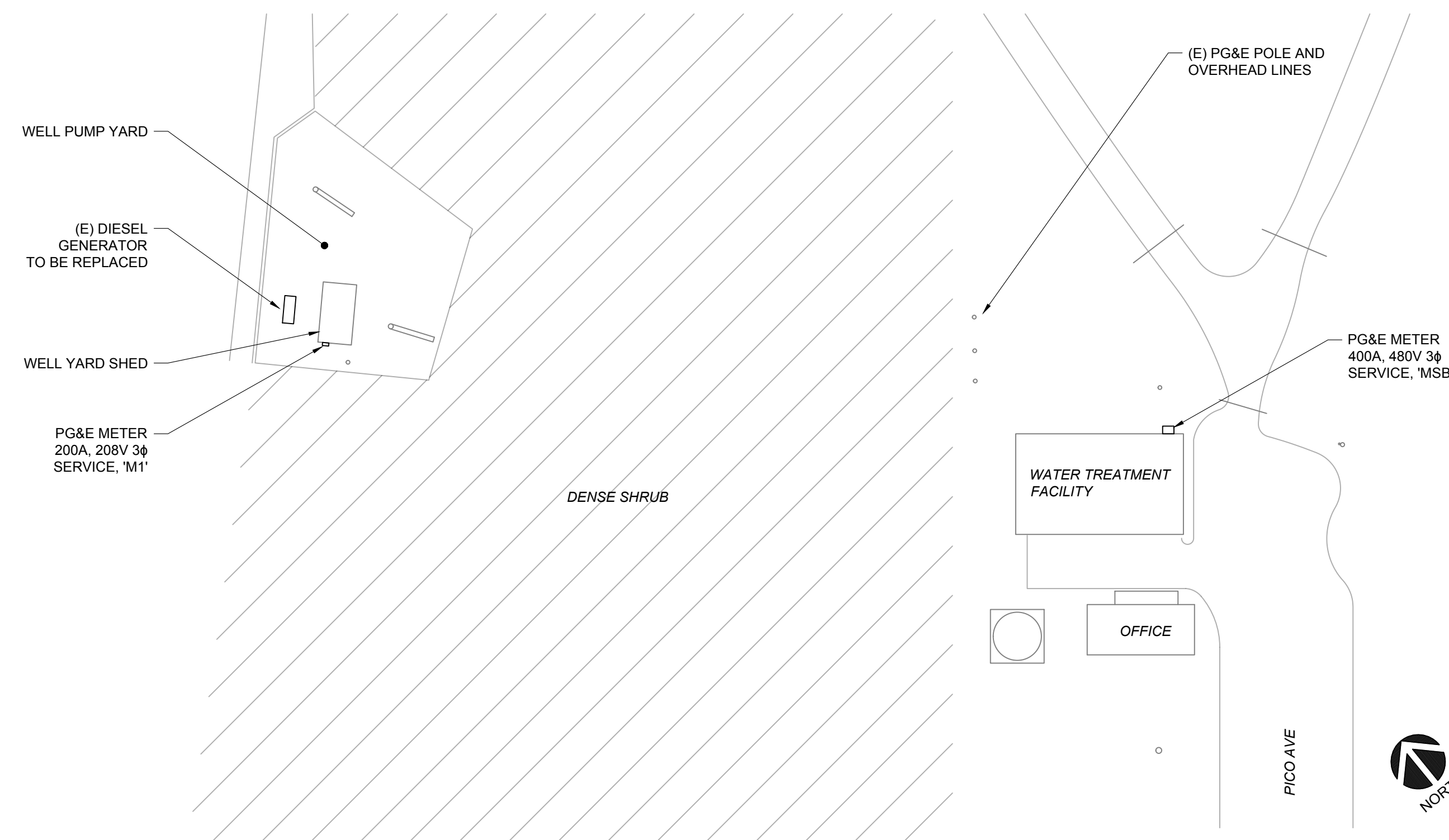

GENERAL PLAN

SCALE: 1/32" = 1'

2
E1

SYMBOLS

	DETAIL REFERENCE; DETAIL NUMBER / SHEET DRAWN
	REFERENCE TO SHEET NOTE
	FUSE
	SWITCH
	METER
	CIRCUIT BREAKER
	CIRCUIT OR CONDUIT ABOVE GRADE
	CIRCUIT OR CONDUIT BELOW GRADE

ABBREVIATIONS

A	AMPERES	HPS	HIGH PRESSURE SODIUM
AC, A/C	ALTERNATING CURRENT,	KVA	KILOVOLT-AMPERES
A.F.F.	AIR CONDITIONING	MCB	MAIN CIRCUIT BREAKER
A.H.J.	ABOVE FINISH FLOOR	MIN/MAX	MINIMUM/MAXIMUM
ATS	AUTHORITY HAVING JURISDICTION	MISC	MISCELLANEOUS
BKR	AUTOMATIC TRANSFER SWITCH	(N)	NEW
BLDG.	BREAKER	NEMA	NATIONAL ELECTRICAL
CEC	BUILDING		MANUFACTURES ASSOC.
C	CALIFORNIA ELECTRICAL CODE	O/H	OVERHEAD
C.B.	CONDUIT	P	POLE
C.O.	CIRCUIT BREAKER	PH	PHASE
COMM	CONDUIT ONLY	P.V.	PHOTOVOLTAIC
CU	COMMUNICATION	RM	ROOM
(E)	COPPER	RMC	RIGID METTALIC CONDUIT
EL OR EM	EXISTING	S.S.	SPECIFICATIONS
EOL	UL LISTED 90-MINUTE EMERGENCY	SWBD	STAINLESS STEEL
E.V.	BALLAST PACK	TYP OR (TYP)	SWITCHBOARD
ES	END-OF-LINE		TYPICAL
(F)	ELECTRIC VEHICLE/EQUIPMENT VENDOR	U/G	UNDERGROUND
GEC	ENERGY SAVING	U.O.N.	UNLESS OTHERWISE NOTED
GES	FUTURE	V	VOLT
GFI	GROUNDING ELECTRODE CONDUCTOR	VAC	VOLTS-AC
GRD	GROUNDING ELECTRODE SYSTEM	VS	VERTICAL SECTION
HP	GROUND FAULT INTERRUPTER	WP	WEATHERPROOF
HPF	GROUND	W	WITH
	HORSEPOWER		
	HIGH POWER FACTOR		

SHEET INDEX

E1	TITLE SHEET AND GENERAL PLAN
E2	ELECTRICAL SITE PLAN
E3	EXISTING SINGLE LINE DIAGRAM
E4	PROPOSED SINGLE LINE DIAGRAM
E5	DETAILS

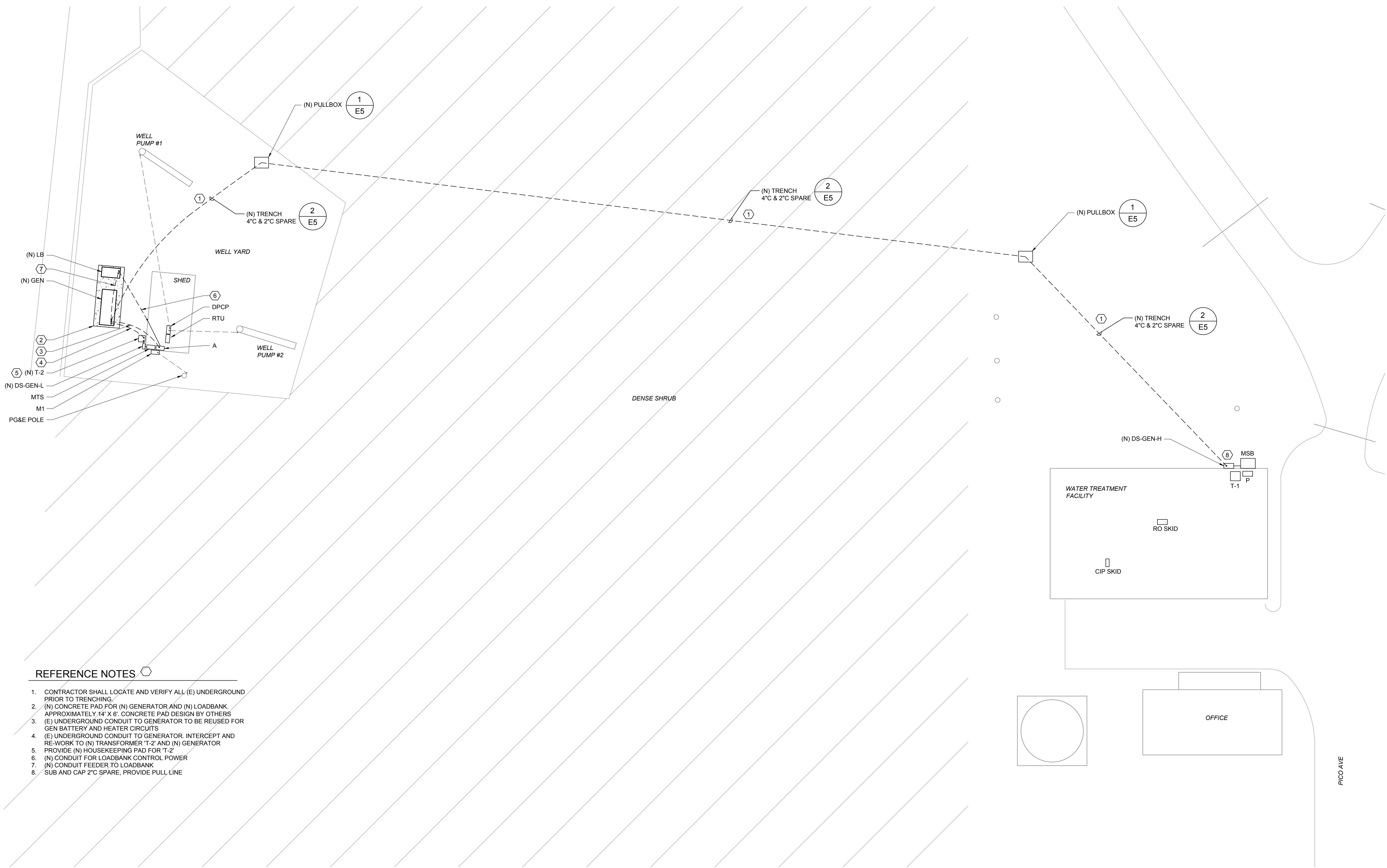

REFERENCE NOTES

1. CONTRACTOR SHALL LOCATE AND VERIFY ALL (E) UNDERGROUND PRIOR TO TRENCHING.
2. (N) CONCRETE PAD FOR (N) GENERATOR AND (N) LOADBANK. APPROXIMATELY 14' X 6'. CONCRETE PAD DESIGN BY OTHERS
3. (E) UNDERGROUND CONDUIT TO GENERATOR TO BE REUSED FOR GEN BATTERY AND HEATER CIRCUITS
4. (E) UNDERGROUND CONDUIT TO GENERATOR. INTERCEPT AND RE-WORK TO (N) TRANSFORMER T-2 AND (N) GENERATOR
5. PROVIDE (N) HOUSEKEEPING PAD FOR T-2
6. (N) CONDUIT FOR LOADBANK CONTROL POWER
7. (N) CONDUIT FEEDER TO LOADBANK
8. SUB AND CAP 2"C SPARE, PROVIDE PULL LINE

SITE PLAN
SCALE: 3/32" = 1'

2
E1

ELECTRICAL ENGINEER
RNM Engineering, Inc.
PO BOX 3343
SAN LUIS OBISPO, CA 93403
(805) 550-6175
chris.stephens@RNM-eng.com



NEW GENERATOR
SAN SIMEON CSD - WATER TREATMENT FACILITY
SAN SIMEON, CA

Date	03/15/2021
Drawn By	CS
Checked By	RNM
Project No.	
Date	Issue
06/08/2020	CUSTOMER REVIEW
01/08/2021	CUSTOMER REVIEW
03/15/2021	100% SUBMITTAL

ELECTRICAL
SITE PLAN

SCALE: AS NOTED

E2

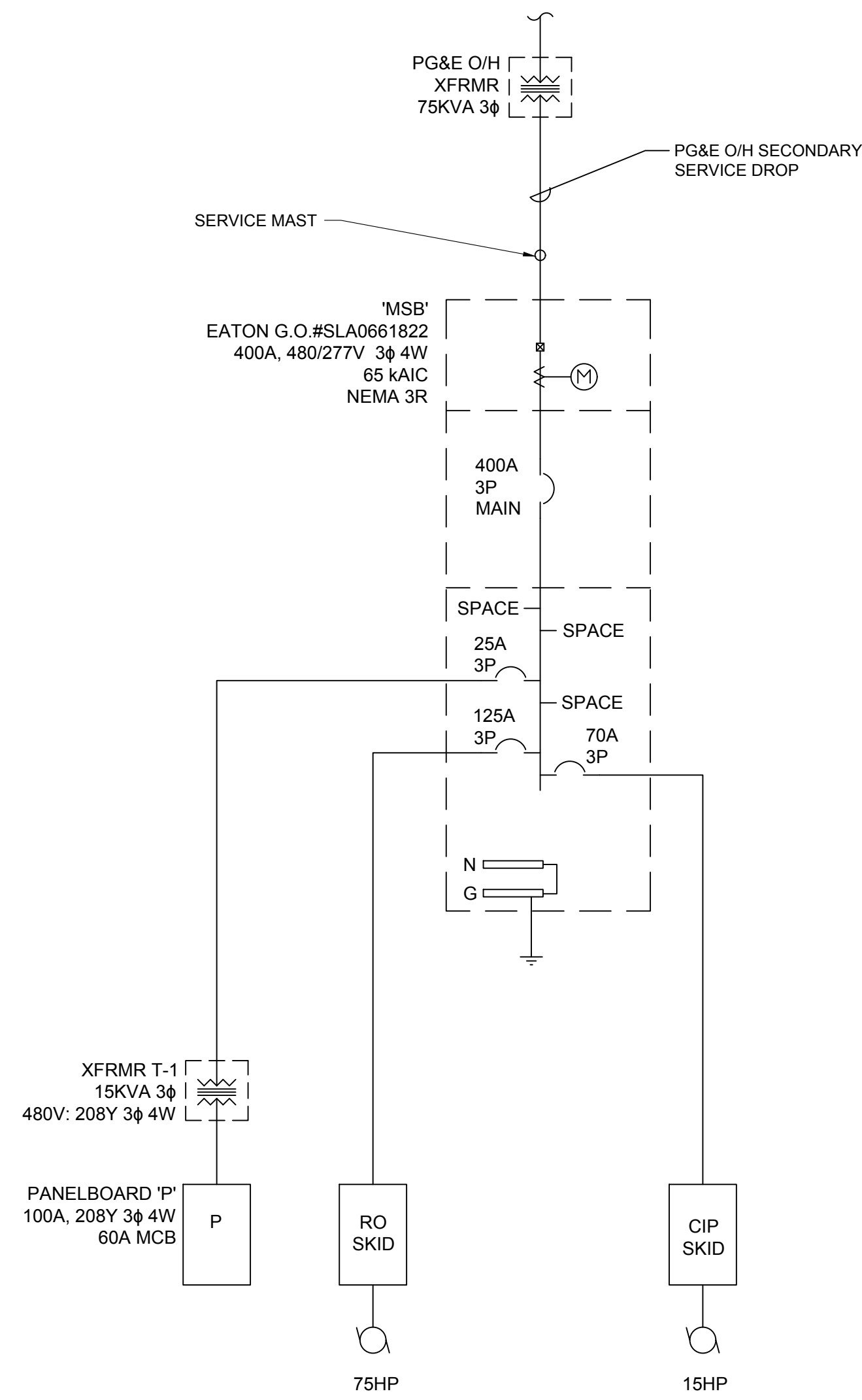

RO AREA

EXISTING SINGLE LINE DIAGRAM

SCALE: NONE

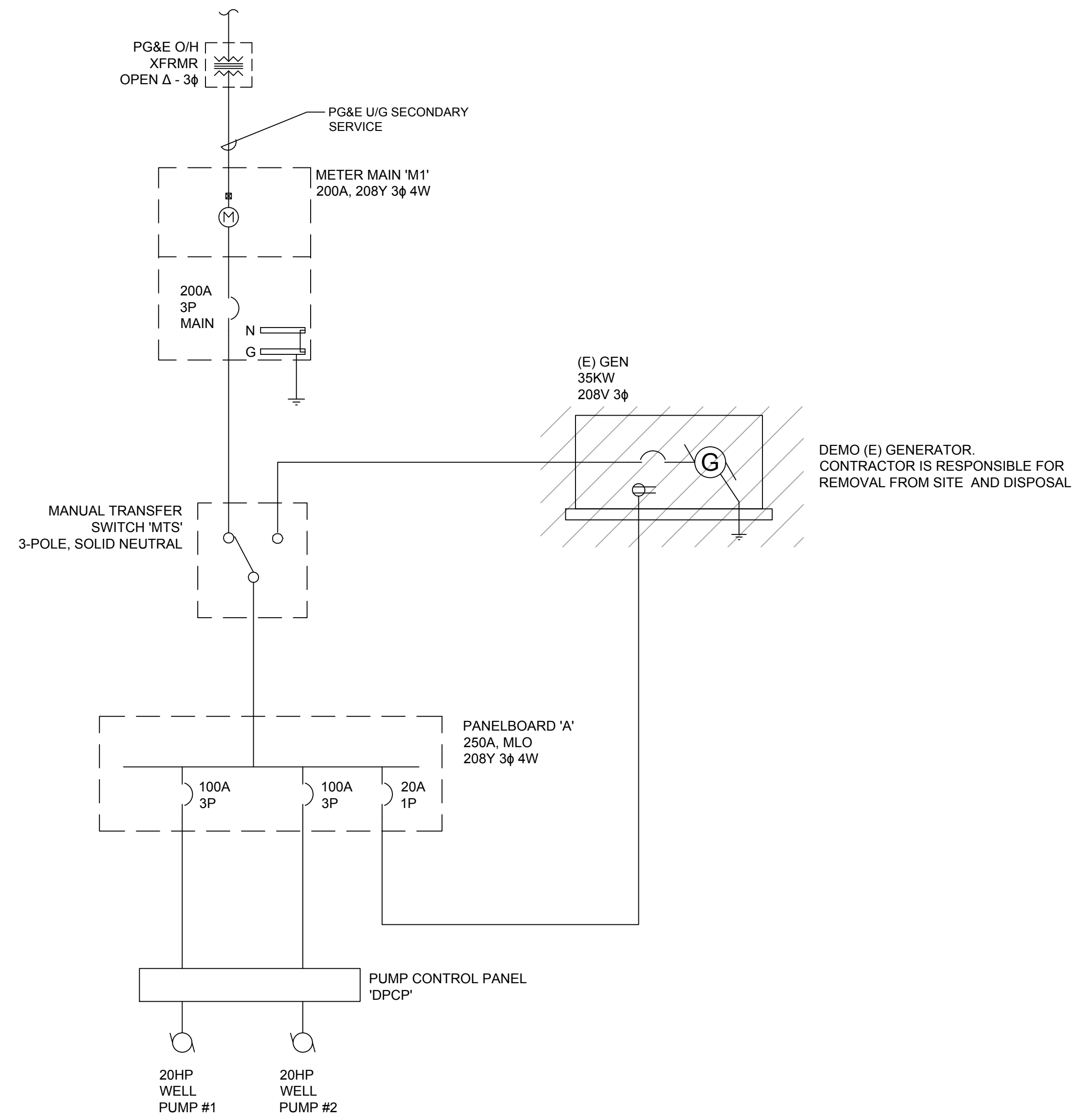

WELL YARD

DEMO (E) GENERATOR.
CONTRACTOR IS RESPONSIBLE FOR
REMOVAL FROM SITE AND DISPOSAL

ALL ITEMS (E) U.O.N. 1
E3

ELECTRICAL ENGINEER

RNM Engineering, Inc.
PO BOX 3343
SAN LUIS OBISPO, CA 93403
(805) 550-6175
chris.stephens@RNM-eng.com



NEW GENERATOR
SAN SIMEON CSD - WATER TREATMENT FACILITY
SAN SIMEON, CA

Date	03/15/2021
Drawn By	CS
Checked By	RNM
Project No.	
Date	Issue
06/08/2020	CUSTOMER REVIEW
01/08/2021	CUSTOMER REVIEW
03/15/2021	100% SUBMITTAL

EXISTING SINGLE LINE DIAGRAM

SCALE: AS NOTED

E3

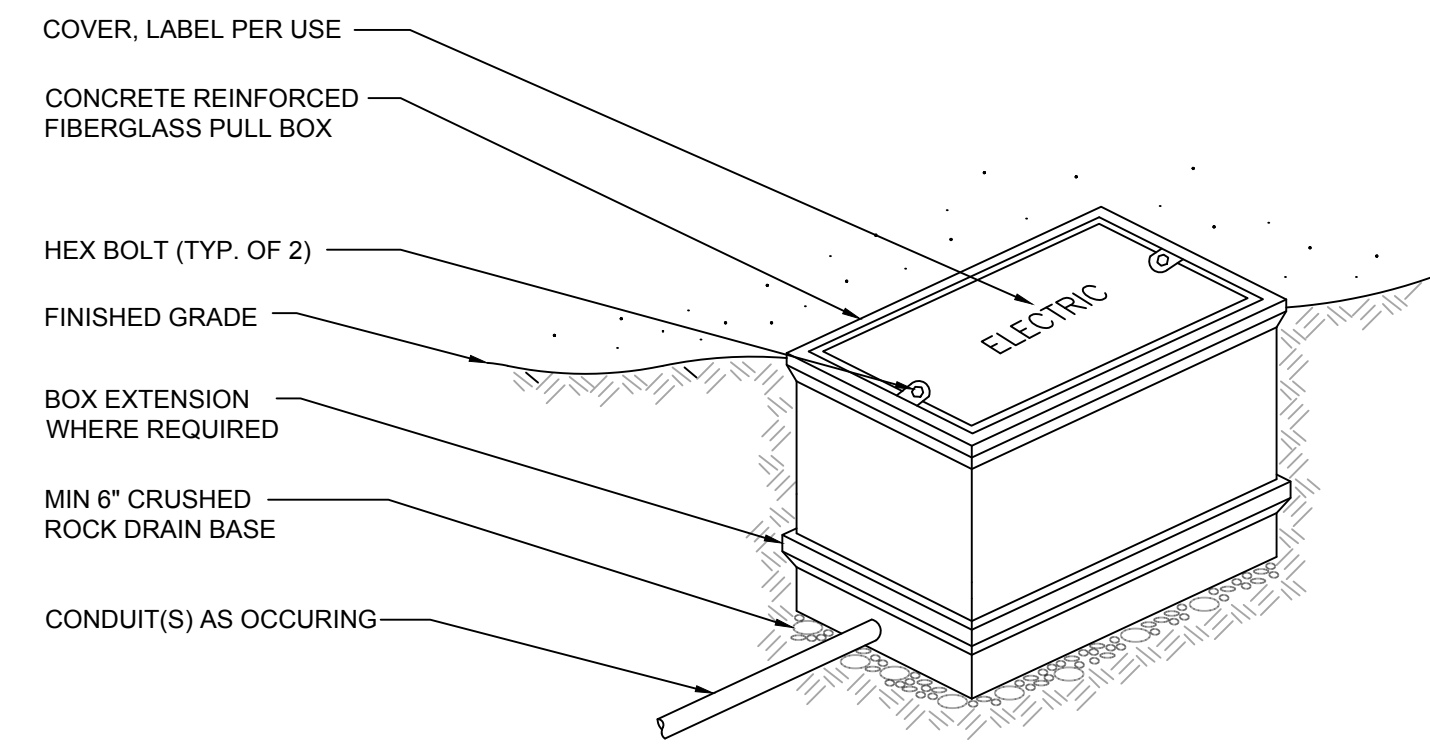

PULLBOX DETAIL

SCALE: NONE

1
E5

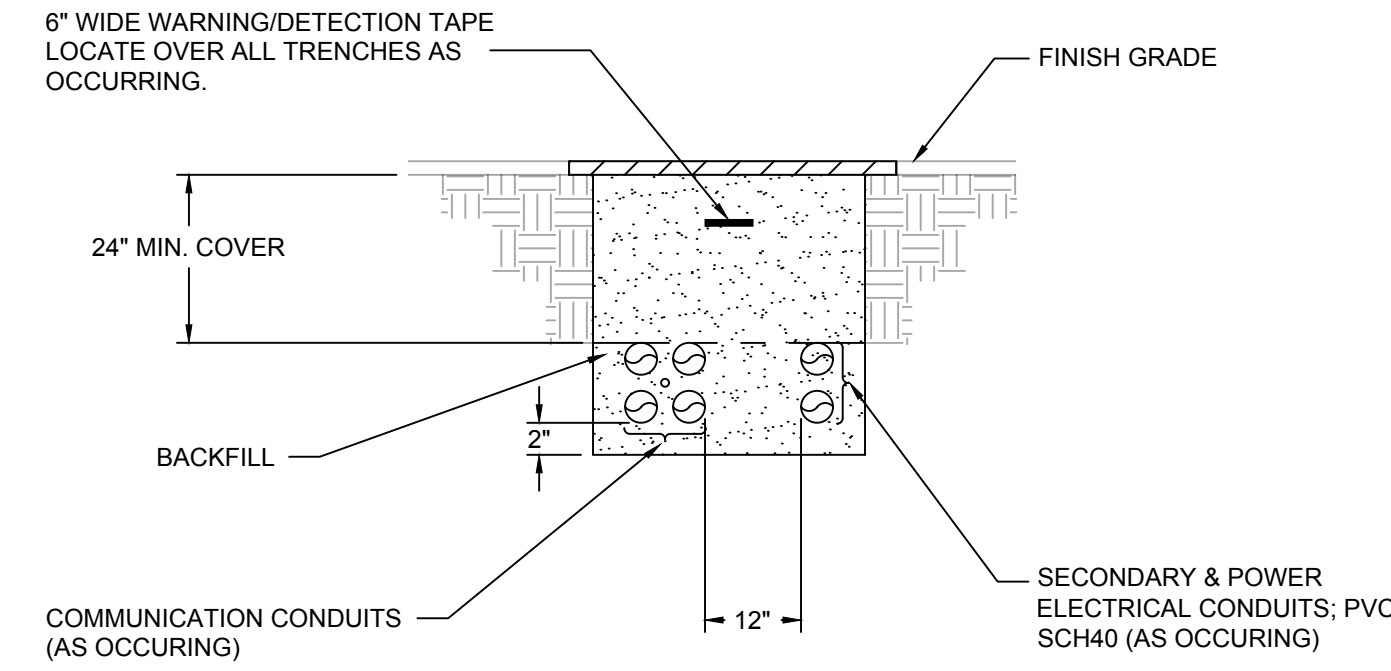

TRENCH DETAIL

SCALE: NONE

2
E5

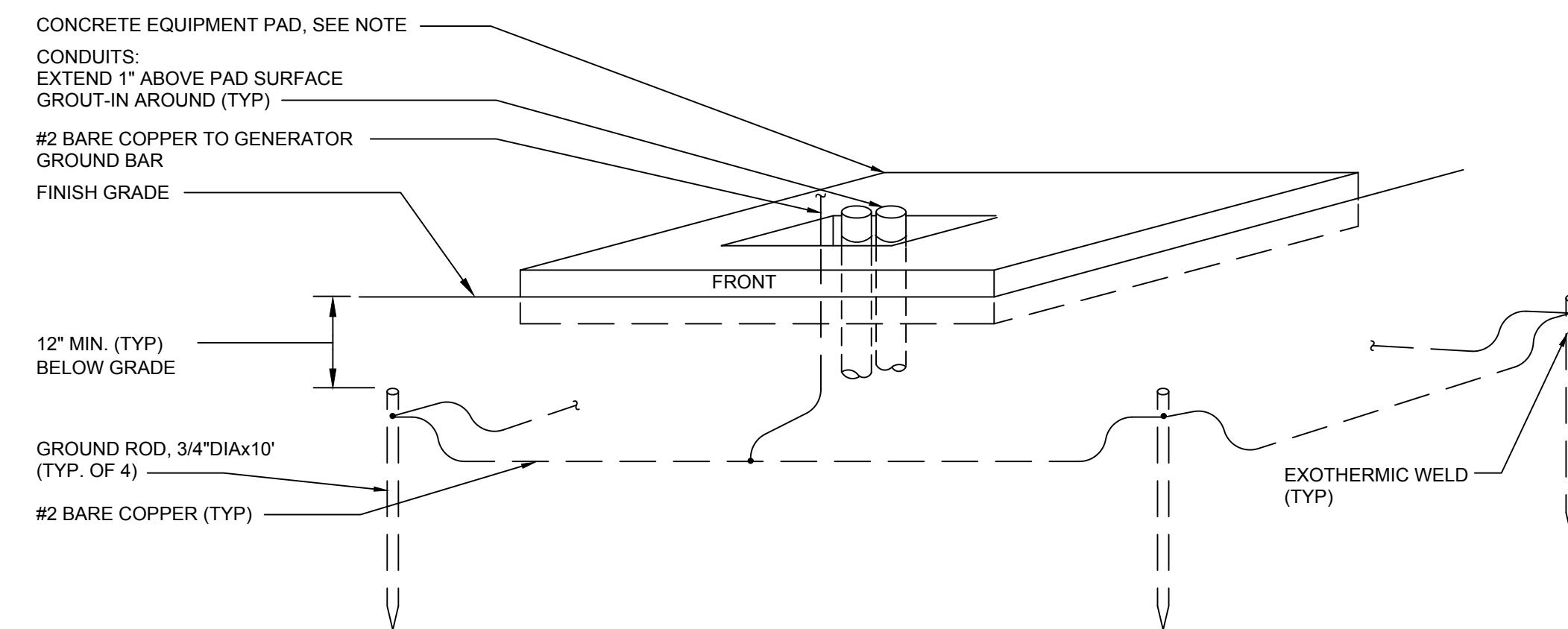

GENERATOR GROUNDING DETAIL

SCALE: NONE

3
E5

PANEL: A		PANEL VOLTAGE: 208 120 3φ - 4W		CODE: N: NON-CONTINUOUS																		
DATE:		BUS: 250A		L: LONG-CONTINUOUS																		
JOB: San Simeon CSD		MAINS: MLO		R: DEMANDABLE RECEPTACLES																		
		AIC RATING: 14,000		M: MECHANICAL																		
				NO OF EQUIP: 9																		
CKT NO	CODE	TRIP	POLE	LOAD DESIGNATION			CONNECTED VA			LOAD DESIGNATION			TRIP	POLE	CODE	CKT NO						
				DESCRIPTION	N	R	L	A	B	C	A	B					C	L	R	N	(NOTE)	DESCRIPTION
1	M	100	3	Well Pump #1	B		1	6500				1000			1	C	Gen Battery Charger	20	1	L	2	
3	M								6500				1800			A	Gen Heater	20	1	L	4	
5	M									6500			500		1	B	DPCP	20	1	L	6	
7	M	100	3	Well Pump #2	B		1	6500				0					Space				N	8
9	M								6500				500			A	Load Bank Control Power	20	1	L	10	
11	M									6500			0				Space				N	12
13	R	20	1	Receptacles	B		1	500				500			1	B	TELM Panel	20	1	L	14	
15	N			Space					0				0				Space				N	16
17	L	20	1	CEM PMP	B		1			1800			0				Space				N	18
19	L	20	1	CEM PMP	B		1	1800					0				Space				N	20
21	N			Space					0				0				Space				N	22
23	L	20	1	Lights	B		1			1000			0				Space				N	24
25	N			Space					0				0				Space				N	26
27	N			Space					0				0				Space				N	28
29	N			Space					0				0				Space				N	30
PANEL NOTES:				Phase Totals: Phase A: 16,800			Phase B: 15300			Phase C: 16,300			TOTAL CONNECTED VA			48,400						
A New													DEMAND N			0						
B Existing													DEMAND L			8900						
C Rework													DEMAND R			500						
D													DEMAND K			0						
A													DEMAND M			39000						
B													PANEL DEMAND VA			48400						
C													PANEL DEMAND AMPS			134.35						
													HIGH PHASE AMPS			139.89						

PANEL SCHEDULE

NEMA 1, SURFACE MOUNTED, EXISTING

ELECTRICAL ENGINEER
RNM Engineering, Inc.
 PO BOX 3343
 SAN LUIS OBISPO, CA 93403
 (805) 560-6175
 chris.stephens@RNM-eng.com



NEW GENERATOR
SAN SIMEON CSD - WATER TREATMENT FACILITY
 SAN SIMEON, CA

Date	03/15/2021
Drawn By	CS
Checked By	RNM
Project No.	
Date	Issue
06/08/2020	CUSTOMER REVIEW
01/08/2021	CUSTOMER REVIEW
03/15/2021	100% SUBMITTAL

DETAILS

SCALE: AS NOTED

E5

7. D. Business Items



BUSINESS ACTION ITEMS STAFF REPORT

Item 7.D. Discussion regarding the Districts existing liability insurance policy with Special District Risk Management Authority (SDRMA) renewal invoice due July 15, 2021.

Summary:

This item was placed on the agenda by direction of Chairperson Kellas. The current policy expires in July 2021 and the current invoice for the 2021/2022 fiscal year is attached.

Enc: Copy of invoice from SDRMA for 2021/2022



Property/Liability Package Program Invoice

Program Year 2021-22

San Simeon Community Services District

111 Pico Avenue
San Simeon, California 93452

Invoice Date: 06/03/2021
Invoice Number: 70527
Member Number: XXXXXXXXXX

Property, Boiler/Machinery, Pollution, Cyber <i>Coverage for 9 reported item(s) valued at (including contents): \$1,064,204</i>	\$4,010.86
Mobile/Contractors Equipment <i>Coverage for 0 reported item(s) valued at: \$0</i>	0.00
General Liability*, Errors & Omissions, Employee & Public Officials Dishonesty <i>Certificates: 1 Non-Member Certificate(s)</i>	8,271.45
Auto Liability (includes \$50 charge for non-owned auto coverage) <i>Coverage for 0 reported item(s) valued at: \$0</i>	50.00
Auto Comp / Collision <i>Coverage for 0 reported item(s) valued at: \$0</i>	0.00
Trailers <i>Coverage for 0 reported item(s) valued at: \$0</i>	0.00

Gross Package Contribution	\$12,332.31
Earned CIP Credits (6)	-463.88
Longevity Distribution Credit	0.00
MemberPlus Online RQ Bonus	-75.00
Other Discounts	0.00
Subtotal	\$11,793.43
5% Multi-Program Discount	\$0.00

Total Contribution Amount Due by July 15 **\$11,793.43**

**Current Limit of Liability is \$2.5M for G/L, A/L and E&O (excluding outside excess liability limits)*

Please pay in full by the due date. If not, a late charge of one percent (1%) per month, twelve percent (12%) per annum, will be assessed on all sums past due. Imposition of this charge does not extend the due date for payment.

For invoice questions call the SDRMA Finance Department.

Special District Risk Management Authority
1112 I Street Suite 300, Sacramento, California 95814-2865
Tel 916.231.4141 or 800.537.7790 | Fax 916.231.4111
www.sdrma.org



Property/Liability Credit Incentive Program



San Simeon Community Services District

CIP Points Earned as of: 3/31/2021

The Credit Incentive Program (CIP) is designed to encourage our Members to take a proactive approach for loss prevention administration, training and safety/risk management. In an effort to assist our Members in achieving the lowest contributions possible, we performed a review of the documents submitted to date for the CIP program year 2020-21. **The CIP points earned will be applied toward the invoice for the 2021-22 program year. However, the actual dollar credit shown as 'Earned CIP Credits' on the invoice may differ from this report due to the actual General and Auto Liability amounts on the invoice.** The following earned credits have been documented:

CIP Criteria Description*	CIPs Earned	CIP \$ Earned	Unearned CIPs	Unearned CIP \$
SDRMA Safety Specialist Certificate	0	\$0	2	\$227
Special District Administrator designation from SDLF	0	\$0	2	\$227
Staff Attendance at SDRMA Workshop	0	\$0	2	\$227
Additional Staff Attendance at SDRMA Workshop	0	\$0	1	\$114
Management Staff Attendance at CSDA Sponsored Training	1	\$114	0	\$0
Additional Management Staff Attendance at CSDA Sponsored Training	0	\$0	1	\$114
Attendance at Approved Legal Seminar	0	\$0	1	\$114
Additional Attendance at Approved Legal Seminar	0	\$0	1	\$114
TargetSolutions Online Training Program	0	\$0	3	\$341
Use of SDRMA Safety Video Library	0	\$0	2	\$227
ADMINISTRATION TRACK TOTALS - 9 POINTS MAXIMUM	1	\$114	8	\$910
SDLF District of Distinction designation	0	\$0	4	\$455
Single Board Member Attendance at SDRMA Workshop	0	\$0	1	\$114
Additional Board Member Attendance at SDRMA Workshop	0	\$0	1	\$114
Single Board Member Attendance at CSDA Training	1	\$114	0	\$0
Additional Board Member Attendance at CSDA Training	0	\$0	1	\$114
Completion of two CSDA Education / Webinar sessions	2	\$227	0	\$0
General Safety Specialist Certificate	0	\$0	1	\$114
GOVERNANCE TRACK TOTALS - 4 POINTS MAXIMUM	3	\$341	1	\$114
No Claims during the year	2	\$227	0	\$0
CLAIMS TRACK TOTALS - 2 POINTS MAXIMUM	2	\$227	0	\$0
COMBINED TRACK TOTALS - 15 POINTS MAXIMUM	6	\$682	9	\$1,024
5 YEAR NO CLAIMS BONUS	0	\$0	3	\$341
TOTAL CREDIT INCENTIVE POINTS	6	\$682	12	\$1,365

*For detailed information, please see the Property/Liability CIP criteria for the applicable Program Year. For questions, please contact us at memberplus@sdrma.org or 800.537.7790.

2021-22 Credit Incentive Program Criteria

Special District Risk Management Authority (SDRMA) is committed to establishing a strategic partnership with our members to provide maximum protection, help control losses and positively impact the overall cost of property/liability coverage through the Credit Incentive Program.

Credit incentives of up to 15 points can be earned based on an Agency's participation in meeting the following program guidelines. One CIP point is equal to a 1% discount on the Agency's Property/Liability Program for the Auto and General Liability net contributions invoice only. Participating members may choose among various options to complete during the CIP period (April 1 – March 31) to reach the maximum points allowable within each track.

The maximum total points a member can receive is 15 points (not including bonus points) and points earned before March 31, 2022 will be applied to the 2022-23 Program Year. Options allowing a member to earn points for both Property/Liability and Workers' Compensation are designated with ***(Credit will be applied to both programs)***. Points are currently awarded as follows:

LOSS PREVENTION TRACK (8 POINTS MAXIMUM)

For staff accredited with the SDRMA General Safety Specialist Certificate or Supervisor Safety Specialist Certificate. This certificate program is a way for the Agency's staff to demonstrate their dedication to safety and loss prevention. The General Safety Specialist certificate requires the Agency employee complete and pass four OSHA certified general training courses and to receive the Supervisor Safety Specialist certificate, complete and pass two supervisory safety courses in addition to the four OSHA certified general training courses. Certificates are valid for 2 years. (Credits earned for first year only)

2 points maximum

No Documentation Required - Will be confirmed by SDRMA.

(Credit will be applied to both programs)

For each full-day attendance by the Agency's safety officer, designated individual, or employee(s) at an SDRMA Safety/Claims Education Day. (First attendee earns 2 points, second attendee earns 1 point)

3 Points maximum

No Documentation Required - Will be confirmed by SDRMA.

(Credit will be applied to both programs)

For management staff or governing body member attending an approved Legal Seminar relating to Employment Practices or Human Resource issues. (Each attendee earns 1 point)

2 Points maximum

Documentation Required – Course syllabus and certificate of completion.

For staff participation in SDRMA's online safety training program – Vector Solutions (formerly TargetSolutions) Safety Programs. 25% of member employees (FT, PT and volunteer firefighters) must each successfully complete a minimum of four individual e-training modules.

3 points maximum

No Documentation Required - Will be confirmed by SDRMA.

Property/Liability Program

For staff participation in defensive driving course for members with scheduled vehicles – all drivers must participate.

2 points maximum

Documentation Required – Course syllabus and certificate of completion of drivers must be submitted to SDRMA for credit.

For members who utilize positive pay on bank accounts for checks, ACH's, and wires.

2 points maximum

Documentation Required – Submit bank documentation annually to SDRMA.

ADMINISTRATION TRACK (2 POINTS MAXIMUM)

For management staff accredited with the Certified Special District Manager (CSDM) designation by the Special District Leadership Foundation (SDLF). This certification program is a way for special district administrators to affirm – to their customers, to their board of directors, and to themselves – that they are competent and experienced in their profession. Requirements for this certification include management experience, continuing education, community service, and ultimately an exam. (Credits earned for first year only)

2 points maximum

No Documentation Required - Will be confirmed by SDLF.

(Credit will be applied to both programs)

For each full-session attendance by the Agency's management staff in a California Special Districts Association (CSDA) sponsored training program, such as CSDA annual conference workshops and/or the Special District Leadership Academy (Each attendee earns 1 point).

2 points maximum

No Documentation Required - Will be confirmed by CSDA.

(Credit will be applied to both programs)

GOVERNANCE TRACK – GOVERNING BODY RELATED (2 POINTS MAXIMUM)

For Agency accredited with District of Distinction designation by the Special District Leadership Foundation (SDLF). This accreditation program enables districts to demonstrate to their communities, the media and legislators their commitment to operate in a sound, responsible manner. Districts apply to SDLF for designation as a "District of Distinction" by submitting financial audits, policies and procedures and proof of Governance and Ethics training received by directors and executive staff. (Credits earned for first year only)

2 points maximum

No Documentation Required - Will be confirmed by SDLF.

(Credit will be applied to both programs)

For each full-session attendance by a member of the Agency's governing body in a California Special Districts Association (CSDA) sponsored training program, such as CSDA annual conference workshops (SDRMA approved), Board Leadership Training, Special District Leadership Academy and/or Special District Leadership Foundation (Each attendee earns 1 point).

2 points maximum

No Documentation Required - Will be confirmed by CSDA training attendance sheet.

(Credit will be applied to both programs)



Property/Liability Program

CLAIMS TRACK (3 POINTS MAXIMUM)

For a participating member agency not having any “paid” **and/or** “filed” claims for one year as well as having a 10-year Loss Ratio 1.0 or less (excluding CAT claims).

1 point

No Documentation Required - Will be confirmed by SDRMA.

For a participating member agency not having any “paid” **and/or** “filed” claims for three years as well as having a 10-year Loss Ratio 1.0 or less (excluding CAT claims).

2 points

No Documentation Required - Will be confirmed by SDRMA.

The following bonus points are in addition to the 15 CIP point limit:

CLAIMS BONUS TRACK (3 POINTS MAXIMUM)

For a participating member agency not having any “paid” **and/or** “filed” claims for five years as well as having a 10-year Loss Ratio 1.0 or less (excluding CAT claims).

3 points

No Documentation Required - Will be confirmed by SDRMA.

CONTACT INFORMATION

For questions regarding point credits or the Credit Incentive Program, please contact SDRMA Chief Risk Officer Debbie Yokota at dyokota@sdrma.org or call the SDRMA office at 800.537.7790.

Also, visit our website at www.sdrma.org, click on MemberPlus Services and then click on Vector Solutions (formerly TargetSolutions) Program to view information about the program Online Certified Safety Training Program Courses available to all members including:

Over 800 member safety-training courses in English and Spanish

- Courses that meet State and Federal government regulations for required contact hours for certified water and wastewater operators
- Courses endorsed by the National Fire Protection Association (NFPA)
- Courses that are recognized and accepted by the California Water Environmental Association (CWEA) and the California Department of Health Services (DHS)
- OSHA approved training courses – 40 new courses
- Professional Development Courses in Leadership, Management, Computer Skills, Customer Service, Finance, Health and Wellness
- Online Driver Training and Compliance Program
- Emergency Vehicle Operator
- Law Enforcement, Online Police Training
- Human Resources

7. E. Business Items



BUSINESS ACTION ITEMS STAFF REPORT

Item 7.E. Discussion regarding the District hiring a public relations consultant.

Summary:

This item was placed on the agenda by direction of Chairperson Kellas.

7. F. Business Items



BUSINESS ACTION ITEMS STAFF REPORT

Item 7.F. Direction to staff regarding the contract with the State of California regarding State Parks' wastewater treatment.

Summary:

The current agreement between the District and State Parks became effective June 10, 1971 and expires fifty (50) years from the date State first released sewage into the sewage treatment facility. Staff is looking for direction from the Board on how to proceed with State Parks.

Enc: Copy of current contract with State Parks

Copy of State Parks Contract

BERNARD S. CROSSMAN (1925-1968)
GERALD C. WEAVER
PAUL A. GEIHS

LAW OFFICES
CROSSMAN, WEAVER & GEIHS
POST OFFICE BOX 155
640 DOLLIVER STREET
PISMO BEACH, CALIFORNIA 93449

TELEPHONE
773-4601
AREA CODE 805

October 25, 1971

Mr. Robert Lankford
San Simeon Acres Community
Services District
P. O. Box 4
San Simeon, CA 93452

Dear Mr. Lankford:

Enclosed is the original Joint Powers Agreement between the District and the State Department of Parks and Recreation which has been duly executed by the State and is being forwarded to you for the District's files.

Very truly yours,

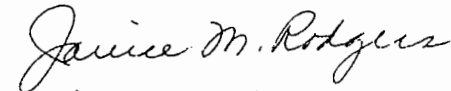

Janice M. Rodgers
Secretary to Mr. Weaver

1 HEARST SAN SIMEON STATE HISTORICAL MONUMENT
2 SEWAGE AGREEMENT

3 THIS AGREEMENT, made and entered into this 10th day of
4 June, 1971, by and between the STATE OF CALIFORNIA,
5 acting through the Department of Parks and Recreation, hereinafter
6 referred to as "STATE" and SAN SIMEON ACRES COMMUNITY SERVICES DISTRICT,
7 hereinafter referred to as the "DISTRICT";

8 W I T N E S S E T H:

9 WHEREAS, DISTRICT owns, operates and maintains sewage
10 collection, transportation, treatment and disposal facilities; and

11 WHEREAS, STATE desires DISTRICT to provide necessary offsite
12 sewer treatment facilities to service Hearst San Simeon State Historical
13 Monument and a portion of San Simeon State Beach formerly known as
14 Hearst Memorial County Park located immediately across Highway 1 from
15 the aforementioned monument; and

16 WHEREAS, DISTRICT, at STATE'S expense, is willing to
17 design and construct necessary offsite sewage treatment facilities
18 to process sewage originating at Hearst San Simeon State Historical
19 Monument and a portion of San Simeon State Beach, formerly known as
20 Hearst Memorial County Park; and

21 WHEREAS, STATE and DISTRICT desire to avail themselves of all
22 provisions of law applicable to this agreement and desire to jointly
23 exercise their powers as specifically provided for under Title I,
24 Division 7, Chapter 5 of the Government Code; and

25 WHEREAS, STATE may, pursuant to Section 5003 of the Public
26 Resources Code, enter into contracts to provide for the care and
27 maintenance and development of the State Park System and to provide
28 funds therefor.

1 NOW, THEREFORE, the parties hereto agree as follows:

2 1. This agreement shall become effective on the date first
3 hereinabove appearing and terminate fifty (50) years from the date
4 STATE first releases sewage into the sewage treatment facility herein
5 provided for. Unless this agreement becomes operative by January 1,
6 1980 with the release of STATE sewage into DISTRICT'S sewerage
7 facilities as herein provided for, this contract shall terminate.

8 2. DISTRICT agrees to construct or cause to be constructed an
9 additional sewage treatment facility with a capacity of 100,000
10 gallons adjacent to its present sewage treatment plant for the purpose
11 of enlarging its existing facilities to provide treatment of a total
12 of 150,000 gallons of sewage per day, including provision for
13 secondary treatment of 50,000 gallons of sewage per day discharged
14 from Hearst San Simeon State Historical Monument and a portion of
15 San Simeon State Beach, formerly known as Hearst Memorial County
16 Park, in accordance with those certain plans and specifications
17 prepared by McCandless-McWherter and Company, Consulting Engineers,
18 Ventura, California, and entitled "Plans For the Construction of
19 Waste Water Treatment Plant Extension for the San Simeon Acres
20 Community Services District" approved by STATE prior to commencement
21 of construction.

22 3. It is understood that said sewage treatment facility shall
23 be of good engineering design and be constructed in a good and workman-
24 like manner meeting STATE'S and DISTRICT'S approval and that upon
25 completion of the sewage treatment facility, it shall become the
26 property of DISTRICT.

27 ---

1 4. STATE shall have the right for the term of this agreement
2 to connect to and discharge into DISTRICT'S sewerage system 50,000
3 gallons of sewage per day and DISTRICT agrees to accept, transport,
4 treat and dispose of said sewage by means of secondary treatment.

5 5. The work to be performed by the DISTRICT, in addition to
6 the actual construction work, shall consist of the preparation of
7 plans, specifications, cost estimates and necessary contract documents,
8 negotiations for necessary rights of way, acquisition of rights of way,
9 easements or other real property interests essential to the construction
10 of said facility, and other preliminary work leading up to the actual
11 construction of the proposed facility.

12 6. DISTRICT agrees to require its contractor or contractors
13 to obtain public liability insurance in the amount of not less than
14 \$100,000.00 for each person and \$300,000.00 for each accident or
15 occurrence with an aggregate limit of \$500,000.00 for claims which
16 may arise from the operations of the contractor or contractors in
17 performance of the work herein provided for and property damage
18 liability in the amount of \$25,000.00 naming the State of California
19 as an additional insured.

20 7. STATE shall pay to DISTRICT a total sum equal to one-half
21 of the cost of construction as defined in paragraph 5 hereof but not
22 to exceed the sum of \$125,000.00 as payment in full for work performed
23 hereunder. Payments of said sum to DISTRICT will be made by STATE
24 monthly by warrant upon presentation of estimates in triplicate
25 prepared, certified and approved by the DISTRICT'S engineer.
26 Payments will be based upon the percentage of work completed
27 during the preceding month and fifty percent (50%) of the value of

1 material incorporated in the work performed and delivered to the
2 job site. The DISTRICT'S engineer shall, as soon as practical after
3 the final acceptance of the work, make a final determination of the
4 amount of work done, and such final determination shall be presented
5 in triplicate to STATE, and STATE shall pay to DISTRICT the entire
6 sum of STATE'S share of costs of construction as herein determined and
7 found to be due after deducting therefrom all previous payments made
8 by STATE but not to exceed in the aggregate the sum of \$125,000.00.

9 8. In the event DISTRICT receives any grant or financial
10 assistance from the United States of America, or the State of California,
11 other than through the State Department of Parks and Recreation,
12 DISTRICT shall repay STATE one-half of the total amount received from
13 any such grant or other financial assistance for the sewage treatment
14 facility herein authorized to be constructed.

15 9. Subject to the availability of funds, STATE shall pay on
16 a quarterly basis in arrears a charge for sewage service provided to
17 STATE upon receipt of an invoice.

18 10. The quarterly charge shall be based on one-fourth of the
19 annual costs necessarily incurred by DISTRICT to transport, treat and
20 dispose of sewage through the operation, maintenance and repair of
21 DISTRICT'S sewage facilities multiplied by a ratio established by
22 dividing total gallonage of sewage discharged from STATE land each
23 quarter by total gallonage of sewage treated in DISTRICT'S sewage
24 treatment facilities for the same quarter. The annual cost figures
25 used to calculate the service charge shall be those for the year
26 immediately prior to the year for which charges are being calculated.
27 For the first year of use of DISTRICT'S facilities by STATE, DISTRICT

1 may adjust said cost figures to allow for the increase in costs due to
2 STATE'S contribution of sewage into DISTRICT'S facilities.

3 11. The determinations as to total gallonage shall be based on
4 metered flows to the extent practical, and where metering is not
5 practicable, the determination shall be mutually agreed upon based
6 upon the engineering and operating data available.

7 12. DISTRICT'S cost for operation, maintenance and repair of
8 the facility shall include all costs for collection, transportation,
9 treatment and disposal of sewage including administrative costs but
10 excluding payments on bonded indebtedness, financing costs, payment
11 of interest or principal on any loan, attorney's fees or other costs
12 in connection with financing any portion of the facility. DISTRICT
13 shall furnish each year a copy of its annual audit report showing
14 its costs together with a statement showing the basis for and
15 computation of said quarterly service charge.

16 13. The attached Fair Employment Practices Addendum,
17 Standard Form 3 (4/65) is incorporated herein for all purposes and
18 made a part hereof and for the purposes of this agreement the term
19 "Contractor" in said Form 3 (4/65) shall mean "DISTRICT".

20 14. DISTRICT hereby waives all claims and recourse against
21 the STATE including the right to contribution for loss or damage
22 to persons or property arising from, growing out of, or in any
23 way connected with or incident to this agreement, except claims
24 arising from the concurrent or sole negligence of STATE, its
25 officers, agents and employees.

26 DISTRICT shall indemnify, hold harmless, and defend
27 STATE, its officers, agents and employees against any and all claims,

1 demands, damages, costs, expenses, or liability costs arising out
2 of the acquisition, development, construction, operation, or
3 maintenance of the property described herein, which claims, demands,
4 or causes of action arising under Government Code Section 895.2 or
5 otherwise, except for liability arising out of the concurrent or sole
6 negligence of STATE, its officers, agents or employees.

7 In the event STATE is named as co-defendant under the
8 provisions of the Government Code Sections 895 et seq., the DISTRICT
9 shall notify STATE of such fact and shall represent itself as co-
10 defendant in such legal action, in which event STATE shall bear its
11 litigation costs, expenses and attorney's fees.

12 In the event judgment is entered against STATE and
13 DISTRICT because of the concurrent negligence of STATE and DISTRICT,
14 their officers, agents, and employees, an apportionment of liability
15 to pay such judgment shall be made by a court of competent
16 jurisdiction. Neither party shall request a jury apportionment.

17 15. Upon completion of construction, DISTRICT shall maintain
18 the sewage treatment facility herein authorized to be constructed
19 in good repair and good working order, provided, however, DISTRICT
20 shall not be obligated to replace any portion of said facility except
21 that necessitated by ordinary wear and tear or act of neglect of
22 the DISTRICT and shall not be obligated to reconstruct said facility
23 or any portion thereof.

24 ---
25 ---
26 ---
27 ---

1
2
3
4
5
6
7
8
9
10
11
12
13
14
15
16
17
18
19

IN WITNESS WHEREOF the parties have caused this agreement
to be executed the date first hereinabove written.

STATE OF CALIFORNIA
DEPARTMENT OF PARKS AND RECREATION
WILLIAM PENN MOTT, JR., Director

By Robert H. Meyer DEPUTY DIRECTOR

SAN SIMEON ACRES COMMUNITY SERVICES
DISTRICT

By Gene Schell

CCRM
VILLAGE OF SAN SIMEON DISTRICT
Department of Parks and Recreation
APPROVED
OCT 22 1971
Frank R. Oliver

Contract#	50-23-004		
Appropriation	Ch. 303/70, Item 346		FY 1971-72
	Ch. 1193/71		
Function or Fund	General, Capital Outlay		
Line Item Allotment	50-71 235290 013.01	\$80,000.00	
	50-72 305290 033.01	\$45,000.00	
Amount of Estimate			\$125,000.00
Unencumbered Remainder			

I Heroby Certify upon my own personal knowledge
that budgeted funds are available for the period and
purpose of the expenditure stated above. (After T.B.A.
No. _____ or B.R. No. _____.)

Gene Schell
Accounting Officer

STATE OF CALIFORNIA)
) ss.
COUNTY OF SAN LUIS OBISPO)

I, ROBERT L. LANKFORD, secretary of the Board of Directors of the San Simeon Acres Community Services District, do hereby certify that the foregoing resolution was duly adopted by the Board of Directors of said District at an adjourned regular meeting of said Board held on the 15th day of September, 1971, and that it was so adopted by the following vote:

AYES: Directors Price, Webster, Stoutsenberger and Scholl

NOES: None

ABSENT: Director Victor

(seal)



Robert L. Lankford
Secretary of the Board of Directors
of the San Simeon Acres Community
Services District

RESOLUTION NO. ~~82~~ 83

A RESOLUTION OF THE BOARD OF DIRECTORS OF
THE SAN SIMEON ACRES COMMUNITY SERVICES
DISTRICT

BE IT RESOLVED by the Board of Directors of
the San Simeon Acres Community Services District as
follows:

1. Said District agrees to and does hereby authorize
Don Scholl, president of the Board of Directors of said
District, to execute on behalf of said District that certain
agreement between said District and the State of California
acting through the Department of Parks and Recreation and
entitled, "Hearst San Simeon State Historical Monument Sewage
Agreement", a copy of which is annexed hereto as Exhibit "A"
to this resolution.

Adopted, signed and approved this 1st day of
September, 1971.

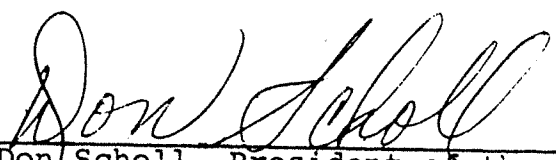

Don Scholl, President of the
Board of Directors of the San
Simeon Acres Community Services
District

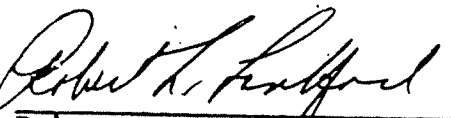
ATTEST:

Robert L. Lankford, Secretary
of the Board of Directors of
the San Simeon Acres Community
Services District

7. G. Business Items



BUSINESS ACTION ITEMS STAFF REPORT

Item 7.G. Discussion regarding public comment and Regular Meeting Agenda layout.

Summary:

This item is placed on the agenda by direction of Chairperson Kellas. In January of 2018 after consensus of the Board, the agenda format was modified. The previous format had two designated public comment portions. One at the beginning of the meeting for items not on the agenda and the second public comment section occurred prior to discussion of the action items. In November of 2018, the Board reached a consensus and directed staff to modify the meeting agenda allowing for three (3) minutes of public comment before each Business Item.

The current agenda format provides for public comment in four (4) places:

- 1) Comment on matters that are not listed on the agenda.
- 2) Comment on Special Presentations and Staff Reports. This allows the public to comment on any matters that were discussed by staff.
- 3) Comment on Consent Agenda Items. This placement allows for the public to comment on items on the consent agenda prior to the Board approving them.
- 4) Comment on Business Action Items. This placement allows for the public to comment for 3 minutes on each item listed under Business Action Items.

Over the last eighteen (18) months the Business Action Items typically list at least five (5) items, which allows for a minimum of fifteen (15) minutes of public comment per person. It is estimated that the amount of allowable public comment under the current agenda format is adding an additional sixty (60) minutes or more to the Board meeting, as resulted in Board meetings are between four (4) and five (5) hours. Designating public comment to the start of each section of the agenda would potentially result in a reduction of legal costs for the community.

Staff has reviewed the agenda formats for several other local agencies. These meeting agendas are attached.

The Board may wish to:

- 1) To change the agenda to the previous public comment format.
- 2) To continue with the current format.
- 3) To reduce the amount of public item allotted for each Business Action item.

Staff is looking for direction from the Board.

Enc: Copy of meeting agenda's from:

San Miguel CSD
Oceano CSD

PAGE INTENTIONALLY LEFT BLANK

PAGE INTENTIONALLY LEFT BLANK



BOARD OF DIRECTORS

Ashley Sangster, President
Ward Roney, Director

Anthony Kalvans, Vice-President
Hector Palafox, Director
Raynette Gregory, Director

REGULAR MEETING AGENDA 6:00 P.M. Closed Session 7:00 P.M. Opened Session SMCSD Boardroom 05-27-2021

IMPORTANT NOTICE REGARDING COVID-19 AND TELECONFERENCE MEETINGS:

Based on the mandates by the Governor in Executive Order 33-20 and the County Public Health Officer to shelter in place and the guidance from the CDC, to minimize the spread of the Corona Virus, please note the following changes to the District's ordinary meeting procedures:

- The District offices are not opened to the public at this time, please call 805-467-3388
- The Meeting will be conducted with social distancing observed.
- All members of the public seeking to observe and comment to the local legislative body may do so in person or telephonically/email in the manner described below.

HOW TO SUBMIT PUBLIC COMMENT IF NOT ATTENDING MEETING:

Written / Read Aloud: Please email your comments to tamara.parent@sanmiguelcsd.org (Board Clerk), write "Public Comment" in the subject line. In the body of the email, include the agenda item number and title, as well as your comments. If you would like your comment to be read aloud at the meeting (keep to three minutes) prominently write "Read Aloud at Meeting" at the top of your email. All comments received before 4:00 PM the day of the meeting will be included as agenda supplement on the District's website under relevant meeting date and will be provided to the Board of Directors.

Voice Mail: Leave a message on the District phone line at 805-467-3388 after 4:30pm before 4:30pm District Staff will take down message. Voice "Public Comment" at beginning of message and include agenda item number and title. All comments received before 4:00 PM the day of the meeting will be included as agenda supplement on the District's website under relevant meeting date and will be provided to the Board of Directors.

PUBLIC RECORD

Public records that relate to any item on the open session agenda for a meeting are available for public inspection. Those records that are distributed after the agenda posting deadline for the meeting are available for public inspection at the same time, they are distributed to all of the members of the Board. The documents may also be obtained by calling the District Board Clerk.

Please see: www.sanmiguelcsd.org

Cell Phones: As a courtesy to others, please silence your cell phone or pager during the meeting and engage in conversations outside the Boardroom.

Americans with Disabilities Act: If you need special assistance to participate in this meeting, please contact the CSD Clerk at (805) 467-3388. Notification 48 hours in advance will enable the CSD to make reasonable arrangements to ensure accessibility to this meeting. Assisted listening devices are available for the hearing impaired.

Public Comment: please see notice.

Please complete a "Request to Speak" form located at the podium in the boardroom in order to address the Board of Directors on any agenda item. Comments are limited to three minutes, unless you have registered your organization with CSD Clerk prior to the meeting. If you wish to speak on an item not on the agenda, you may do so under "Oral Communications." Any member of the public may address the Board of Directors on items on the Consent Calendar. Please complete a "Request to Speak" form as noted above and mark which item number you wish to address.

Meeting Schedule: Regular Board of Director meetings are generally held in the SMCSO Boardroom on the fourth Thursday of each month at 7:00 P.M. Agendas are also posted at: www.sanmiguelcsd.org

Agendas: Agenda packets are available for public inspection 72 hours prior to the scheduled meeting at the Counter/ San Miguel CSD office located at 1150 Mission St., San Miguel, during normal business hours. Any agenda-related writings or documents provided to a majority of the Board of Directors after distribution of the agenda packet are available for public inspection at the same time at the counter/ San Miguel CSD office at 1150 Mission St., San Miguel, during normal business hours.

I. Call to Order: 6:00 PM

II. Pledge of Allegiance:

III. Roll Call: *Sangster* ___ *Kalvans* ___ *Roney* ___ *Palafos* ___ *Gregory* ___

IV. Approval of Regular Meeting Agenda:

M_____ S_____ V_____

V. ADJOURN TO CLOSED SESSION: Public Comment for items on closed session agenda
Time: _____

A. CLOSED SESSION AGENDA:

- 1. CONFERENCE WITH LEGAL COUNSEL—ANTICIPATED LITIGATION**
Significant exposure to litigation pursuant to paragraph (2) of subdivision (d) of Section 54956.9: Confidential Complainant
- 2. PUBLIC EMPLOYEE PERFORMANCE EVALUATION**
(Pursuant to Government Code §54957) Title: Interim General Manager/Fire Chief
- 3. PUBLIC EMPLOYMENT**
Title: Interim General Manager/Fire Chief; Pursuant to Government Code Section 54954.5
- 4. CONFERENCE WITH DISTRICT GENERAL COUNSEL-ANTICIPATED LITIGATION**
Initiation of litigation pursuant to paragraph (4) of subdivision (d) of Section 54956.9: White Oak

VI. Call to Order for Regular Board Meeting/Report out of Closed Session 7:00 PM

Time: _____

1. Report out of closed session by District General Counsel (WhiteBrenner, LLP)

VII. Public Comment and Communications for items not on the Agenda:

Persons wishing to speak on a matter not on the agenda may be heard at this time; however, no action will be taken until placed on a future agenda. Speakers are limited to three minutes. Please complete a "Request to Speak" form and place in basket provided.

VIII. Special Presentations/Public Hearings/Other:

1. **PUBLIC HEARING:** Consider Adoption of Resolution No. 2021-13 Adopting the FY 2021-22 Operations and Maintenance Budget.

Recommendation: After Public Hearing; Approve Resolution 2021-13 Adopting the FY 2021-22 Operation and Maintenance Budget.

Public Comments: (Hear public comments prior to Board Action)

M _____ S _____ V _____

IX. Staff & Committee Reports – Receive & File:

Non-District Reports:

- | | | |
|----|---|-----------|
| 1. | San Luis Obispo County | No Report |
| 2. | Camp Roberts—Army National Guard (Mitten) | Verbal |
| 3. | Community Service Organizations | Verbal |

District Staff & Committee Reports:

- | | | | |
|----|--------------------------|------------------|-----------------|
| 4. | Interim General Manager | (Mr. Roberson) | Verbal |
| 5. | District General Counsel | (Mr. White) | Verbal |
| 6. | District Engineer | (Dr. Reely) | Report Attached |
| 7. | Director of Utilities | (Mr. Dodds) | Report Attached |
| 8. | Fire Chief | (Chief Roberson) | Report Attached |

X. CONSENT CALENDAR:

The items listed below are scheduled for consideration as a group and one vote. Any Director or a member of the public may request an item be withdrawn from the Consent Agenda to discuss or to change the recommended course of action. Unless an item is pulled for separate consideration by the Board, the following items are recommended for approval without further discussion.

1. Review and Approve Board Meeting Minutes

- a) 3-25-2021 Regular Board Meeting
- b) 4-16-2021 Special Board Meeting
- c) 5-6-2021 3rd Strategic Planning Informal Work Session- Fire
- d) 5-13-2021 4th Strategic Planning Informal Work Session- LAFCO

XI. BOARD ACTION ITEMS:

1. Review, Discuss, Receive and File the Enumeration of Financial Report for April 2021 (Dodds)

- A. Claims Detail Report
- B. Statement of Revenue Budget vs Actuals
- C. Rev Budget vs Actual Summary
- D. Statement of Expenditures Budget vs Actual
- E. Cash Report

Public Comments: (Hear public comments prior to Board Action)

M _____ S _____ V _____

2. Review and approve Resolution 2021-14 authorizing the Director of Utilities to contract with B&T Service Station Contractors in an amount not to exceed \$105,000 to provide a turnkey fuel tank and fuel management system at the Machado WWTF and authorize a budget adjustment in an amount of \$120,000 divided equally from all Funds (object 500) from capital reserve. (Dodds)

Recommendation: Approve Resolution 2021-14 authorizing the Director of Utilities to contract with B&T Service Station Contractors and authorizing a corresponding Budget adjustment.

Public Comments: (Hear public comments prior to Board Action)

M _____ S _____ V _____

3. Review final project report for 10th and 11th street waterline replacement project and approve RESOLUTION 2021-15 accepting this completed project. (Dodds)

Recommendation: Review final project report for 10th and 11th street waterline replacement project and approve Resolution 2021-15 accepting this completed project.

Public Comments: (Hear public comments prior to Board Action)

M _____ S _____ V _____

4. Adoption of RESOLUTION NO. 2021-16 authorizing the abatement of weeds within the District boundaries. (Young/ Roberson)

Recommendation: Staff requests that the Board hold a discussion to consider objections to the “Notice to Remove, Destroy, and/or Abate Vegetation, Rubbish and Debris”, overrule any objections and adopt Resolution No 2021-16 authorizing Fire Chief to have weed abatement work performed.

Public Comments: (Hear public comments prior to Board Action)

M _____ S _____ V _____

5. Continued discussion on the Fire Department Temporary Housing unit (Young)

Recommendation: Discuss the status and next steps for the Fire Department Temporary Housing unit

Public Comments: (Hear public comments)

6. Discussion on status of Machado Wastewater Treatment Facility expansion and aeration upgrade project (Dodds)

Recommendation: Discuss the status and next steps of the Machado Wastewater Treatment Facility expansion and aeration upgrade projects.

XII. BOARD COMMENT:

This section is intended as an opportunity for Board members to make brief announcements, request information from staff request future agenda item(s) and/or report on their own activities related to District business. No action is to be taken until an item is placed on a future agenda.

XIII. ADJOURNMENT TO NEXT REGULAR MEETING

ATTEST:

STATE OF CALIFORNIA)
COUNTY OF SAN LUIS OBISPO) ss.
COMMUNITY OF SAN MIGUEL)

I, Tamara Parent, Board Clerk of San Miguel Community Services District, hereby certify that I caused the posting of this agenda at the SMCSO office on May 21, 2021

Date: May 21, 2021

Rob Roberson, Fire Chief/Interim General Manager
Ashley Sangster, SMCSO Board President 2021
Tamara Parent, Board Clerk

PAGE INTENTIONALLY LEFT BLANK



AGENDA Pismo Beach Planning Commission Tuesday, June 8, 2021

Zoom Meeting ID: 816 3699 0268 - Toll-Free Access Number (888) 788-0099
Zoom Meeting Link - <https://us02web.zoom.us/j/81636990268>

0. VIRTUAL MEETING INSTRUCTIONS:

To continue conducting the people's business within San Luis Obispo County, State of California, and CDC health and safety guidelines, this Planning Commission meeting is being conducted in a hybrid virtual format with virtual public participation only.

Watch and Listen to the Meeting

- **Watch and listen to the meeting live at pismo beach.org/agenda.** A link to view the live meeting will appear when the broadcast begins. Meetings may begin shortly after their scheduled start.
- **Watch and listen to the meeting live on Charter Spectrum Cable Channel 20** in Pismo Beach.
- **Watch and listen to the meeting using the Zoom software client** by clicking this link or typing this URL into your web browser: <https://us02web.zoom.us/j/81636990268>. The meeting ID may also be typed into the Zoom software client after clicking "Join Meeting."
- **Listen to the meeting by phone** by calling (888) 788-0099 or (877) 853-5247 and entering Zoom Meeting ID: 816 3699 0268. Please note that the phone numbers of callers may be visible to other meeting participants, or in meeting recordings. Members of the public may create free Zoom accounts in order to change their screen names via the Zoom software when joining the virtual call.

Provide Public Comment

In the interest of public health and safety, in-person public access is not available at this time for the agendized public comment periods. Alternative ways to submit comment are provided below.

To submit general public comment, or public comment on agenda item(s), you may:

- **Email planningcommission@pismo beach.org before the meeting; or during the meeting no later than the start of the comment period for your item of interest.** Emailed comments will be received directly by the Planning Commission. For the regular meeting, commenters wishing to display written comment or pictorial exhibit during a comment period must email the materials ahead of the comment period in order to enable staff to display the materials on screen.
- **Provide oral comment via the Zoom software client** by clicking this link, or typing this URL into your web browser <https://us02web.zoom.us/j/81636990268> The meeting ID may also be typed into the Zoom software client after clicking "Join Meeting." Once connected, wait to be prompted by the Chair or Clerk during your item of interest. Please use the "raise hand" feature at the appropriate time to indicate that you wish to comment.
- **Provide oral comment by phone** by calling (888) 788-0099 or (877) 853-5247 and entering Zoom Meeting ID: 816 3699 0268, then waiting to be prompted by the Chair or Clerk during your item of interest. Please press *9 to "raise your hand" at the appropriate time to indicate that you wish to comment. Please note that the phone numbers of callers may be visible to other meeting participants, or in meeting recordings. Members of the public may create free Zoom accounts in order to change their screen names via the Zoom software when joining the virtual call.
- **Call 805-556-8299 and leave a voicemail before the meeting; or during the meeting no later than the start of the comment period for your item of interest.** A transcript of voicemails received will be forwarded to the Planning Commission as soon as received by the Clerk. This phone number is an automated voicemail line only and will not be answered or monitored for other purposes; please note that phone numbers of voicemail commenters may be visible in the public record along with voicemail transcripts.

Please contact Administrative Secretary / Clerk at eperez@pismo beach.org with questions.

(Agenda begins on next page)

Regular Meeting—6:00 p.m.
Council Chamber, 760 Mattie Road, Pismo Beach, CA 93449
(no in-person public access permitted)
Zoom Meeting ID: 816 3699 0268 - Toll-Free Access Number (888) 788-0099
Zoom Meeting Link - <https://us02web.zoom.us/j/81636990268>

CALL TO ORDER: Chair Inman

1. ROLL CALL

Chair: Inman
 Vice-Chair: Werner
 Planning Commissioners: Jones, Malone Prichard, Van Rozeboom

2. PLEDGE OF ALLEGIANCE

The Pledge of Allegiance will not be conducted as part of this virtual meeting.

3. PUBLIC COMMENT PERIOD

At this time, members of the public may comment on any item NOT appearing on the agenda. For items appearing on the agenda, including the Consent Calendar, the public will be invited to make comments during Commission consideration of the item. In accordance with state law, matters raised as part of this comment period cannot be discussed or acted upon by the Commission at this time. However, in response to a matter raised as part of this comment period, the Commission may, during the Planning Commission Comments and Requests, direct staff to assist a speaker, or schedule the matter for consideration on a future agenda. Please adhere to the following procedures when addressing the Commission:

- **Please limit your comments to 3 minutes or less.**
- Unduly disruptive behavior will not be permitted.

Documents submitted to the Commission become public record unless otherwise exempt from disclosure.

4. CONSENT CALENDAR

All Consent Calendar items will be acted upon by a single action of the Planning Commission unless otherwise requested by an individual Commissioner for separate consideration. Public comment on Consent Calendar items will be invited prior to action on the Calendar.

Item 4.A: ADOPTION OF MEETING MINUTES OF THE MAY 11, 2021, REGULAR MEETING. (PEREZ)

Recommendation: Adopt Minutes of the May 11, 2021, Regular Meeting

5. ITEMS PULLED FROM CONSENT CALENDAR

6. PUBLIC HEARING AGENDA

GENERAL PROCEDURES FOR PUBLIC HEARINGS (Chair/Presiding Officer reserves discretion to set speaking allowances):

1. City staff will present the staff report and recommendation, and respond to technical/clarifying questions from Commission
2. Chair will open the public hearing, and invite the project applicant, or representative, to present the project (Limited to 10 mins);
3. In an Appeal Hearing, the Chair will then invite the appellant, or representative, to present their appeal (Limited to 10 mins);
4. Chair will then ask other interested persons to testify regarding the project (Limited to 3 mins per speaker);
5. Chair will invite the project applicant, or representative, to make a rebuttal if desired (Limited to 5 mins);
6. In an Appeal Hearing, the chair will then invite the appellant, or representative, to make a rebuttal if desired (Limited to 5 mins);
7. Chair will close the public hearing, following which the Commission will deliberate and act on the matter.

Item 6.A: TENTATIVE PARCEL MAP, CONDITIONAL USE PERMIT, COASTAL DEVELOPMENT PERMIT, AND ARCHITECTURAL REVIEW PERMIT TO SUBDIVIDE A LEGAL PARCEL INTO THREE PARCELS, DEMOLISH AN EXISTING RESIDENCE AND CONSTRUCT THREE DETACHED SINGLE-FAMILY RESIDENCES (P20-000071), AND CATEGORICAL EXEMPTION NO. 2021-017; LOCATION – 478 HINDS AVENUE; THE PROJECT IS LOCATED INSIDE THE COASTAL ZONE AND IS NOT APPEALABLE TO THE COASTAL COMMISSION; APN: 005-085-006. (NYGAARD)

Recommendation: Adopt a Resolution approving Project P20-000071 for a Tentative Parcel Map, Conditional Use Permit, Coastal Development Permit, and Architectural Review Permit for three new lots, demolition of an existing residence, and for the construction of three new residences and adopting Categorical Exemption No. 2021-017.

7. BUSINESS ITEMS

8. PLANNING COMMISSION COMMENTS AND REQUESTS

9. DIRECTOR COMMENTS

10. ADJOURNMENT

To the following meeting(s). Meetings will be held at City Hall 760 Mattie Road, Pismo Beach, CA 93449 unless otherwise noted:

Meeting	Time	Date	Location
Regular Meeting	6:00 p.m.	Tuesday, June 22, 2021	Council Chamber, City Hall

Regular Planning Commission meetings will adjourn by 10:00 p.m. unless four-fifths of the Commission votes to continue past that time. If the meeting is adjourned at 10:00 p.m., any remaining agenda items will be continued to the next regular meeting.

AFFIDAVIT OF POSTING

I, Elsa Perez, Administrative Secretary for the City of Pismo Beach, declare under penalty of perjury that the foregoing agenda for the June 8, 2021, meeting of the Pismo Beach Planning Commission was posted on June 3, 2021, at City Hall, located at 760 Mattie Road, Pismo Beach, CA, as well as on the City's website.

 Elsa Perez, Administrative Secretary

Meeting Schedule: The Planning Commission of Pismo Beach regularly meets on the second and fourth Tuesdays of each month at 6:00 p.m., unless otherwise noticed. Workshops and Special meetings will be duly noticed as needed. (R-2020-014)

Agendas: Agendas for Regular Meetings are available for public review on the City's website at pismo-beach.org/agenda and in the City Clerk's Office, 760 Mattie Road, Pismo Beach after 5:00 p.m. on the Friday prior to the meeting. Agendas for Special meetings are available no fewer than 72 hours prior to the meeting when possible.

Related Materials: Materials related to an item on this agenda submitted to the Commission after distribution of the agenda packet are available for public inspection in the Planning Division Office, 760 Mattie Road, Pismo Beach during normal business hours. Such documents are also available on the City of Pismo Beach Public Records Portal pismo-beach.org/accesspismo subject to staff's ability to post the documents before the meeting.

Broadcasting: Regular (televised) Planning Commission meetings are available for viewing 24/7 at pismo-beach.org/agenda using the City's web streaming module and the week of Planning Commission meetings on Channel 20, three times a day at 1:00 a.m., 9:00 a.m., and 6:00 p.m.

Use of Equipment: Please contact the City Clerk's Office if requesting to use the chamber equipment during public comment or as part of a scheduled presentation, 24 hours prior to the meeting at (805) 773-7003.

Notice Regarding Americans with Disabilities Act



In compliance with the Americans with Disabilities Act, if you need special assistance to participate in this meeting or if you need agenda documents provided in an alternative format, please contact the City Clerk's Office at 773-7003 as soon as possible prior to the meeting to ensure that reasonable arrangements can be made (28CFR 35.102-35.104 ADA Title II).

PAGE INTENTIONALLY LEFT BLANK

Pursuant to Governor Newsom's Executive Order N-29-20, members of the Board of Directors, staff and public may participate in this meeting via teleconference and/or electronically. The Oceano Community Services District Boardroom will NOT be open for accessing the meeting.



Notice of Regular Meeting
Oceano Community Services District - Board of Directors Agenda
WEDNESDAY, MAY 26, 2021 – 6:00 P.M.
Location: TELECONFERENCE – SEE BELOW

HOW TO OBSERVE THE MEETING

This meeting will be conducted using Zoom software, which requires a name/email to be entered prior to accessing the meeting. This is not a District requirement for participation. Public participants are welcome to use an anonymous name/email if preferred.

Telephone: Listen to the meeting live by dialing (669) 900-9128 or (253) 215-8782. Enter **Meeting ID# 892-6279-7188** followed by the pound (#) key. Then enter the **Password: 508435** followed by the pound (#) key. If the line is busy, additional phone numbers can be found on Zoom's website at <https://zoom.us/u/abb4GNs5xM>

Computer: With internet access use the **Password: 508435** to watch the live streaming at <https://us02web.zoom.us/j/89262797188?pwd=Q2lUeVc5THhnZk10TETtOUTITcXRIzZz09> or by going to zoom.us and selecting "Join A Meeting" then entering the **Meeting ID# 892-6279-7188** followed by the **Password: 508435**

Mobile: Log in through the Zoom Mobile App on a smartphone or tablet and enter **Meeting ID#: 892-6279-7188** then enter the **Password: 508435**.

For information on Zoom's system requirements please visit: <https://support.zoom.us/hc/en-us/articles/201362023-System-Requirements-for-PC-Mac-and-Linux>

HOW TO SUBMIT PUBLIC COMMENTS

Before the Meeting: Please email your comments to carey@oceanocsd.org with "Public Comment" in the subject line. In your email please include the agenda item number and title and your comments. You may also provide public comment through the District website at: <https://oceanocsd.org/contact/>. All comments received before 12:00 p.m. the day of the meeting will be included as an agenda supplement on the District's website <https://oceanocsd.org/meeting-agendas-minutes/agenda-packets/> and provided to the Directors prior to the meeting. Comments received after the deadline, but prior to the meeting start time, will be attached to the minutes of the meeting.

Live Comments: During the meeting, the Board President or designee will announce the opportunity for public comment. Members of the public may utilize the "raise hand" feature in Zoom to be placed into the speaking queue. Each individual speaker is limited to a presentation time of THREE (3) minutes per item. Persons wishing to speak on more than one item shall limit his/her remarks to a total of SIX (6) minutes. This time may be allocated between items in one-minute increments up to three minutes. Time limits may not be yielded to or shared with other speakers.

To "Raise Hand:"

- **Telephone:** Press " * 9 " to raise your hand to notify meeting host and be placed in the queue. The host will unmute and call on you when it's your time to speak.
- **Computer/Mobile Device:** Click the "raise hand" button to notify meeting host and be placed in the queue. The host will unmute and call on you when it's your time to speak. If the "raise hand" button is not displayed on the screen, please click the "participants" icon at the bottom of the screen and the "raise hand" button will appear.

All items on the agenda including information items, may be deliberated. Any member of the public with an interest in one of these items should review the background material and request information on the possible action that could be taken.

1. CALL TO ORDER
2. ROLL CALL
3. FLAG SALUTE
4. AGENDA REVIEW
5. PUBLIC COMMENT ON MATTERS NOT ON THE AGENDA

This public comment period provides an opportunity for members of the public to address the Board on matters of interest within the jurisdiction of the District that are not listed on the agenda. If a member of the public wishes to speak at this time, Public comment is limited to three (3) minutes.

6. SPECIAL PRESENTATIONS & REPORTS:

A. STAFF REPORTS:

- i. Sheriff's South Station - Commander Jay Wells
- ii. FCFA Operations - Chief Steve Lieberman
- iii. Operations – Utility System Manager Tony Marraccino
- iv. OCSD General Manager – Will Clemens

B. BOARD OF DIRECTORS AND OUTSIDE COMMITTEE REPORTS:

- i. Director Villa
- ii. Director Gibson
- iii. Vice President White
- iv. President Austin
- v. Director Replogle

C. PUBLIC COMMENT ON SPECIAL PRESENTATIONS AND REPORTS:

This public comment period provides an opportunity for members of the public to address the Board on matters discussed during Special Presentations and Reports. If a member of the public wishes to speak at this time, Public comment is limited to three (3) minutes.

7. CONSENT AGENDA ITEMS:

Public comment Members of the public wishing to speak on consent agenda items may do so when recognized by the Presiding Officer. If a member of the public wishes to speak at this time, Public comment is limited to three (3) minutes.

- A. Review and Approval of Minutes for the Regular Meeting of May 21, 2021
- B. Review of Cash Disbursements

8. BUSINESS ITEMS:

Public comment Members of the public wishing to speak on business items may do so when recognized by the Presiding Officer. If a member of the public wishes to speak at this time, Public comment is limited to three (3) minutes.

- A. Presentation by One Cool Earth regarding their "Earth Genius" program at Oceano Elementary School.
- B. Workshop on the 2021-2022 Budget with Board direction as deemed appropriate.

9. HEARING ITEMS:

Public comment Members of the public wishing to speak on hearing items may do so when recognized by the Presiding Officer. If a member of the public wishes to speak at this time, Public comment is limited to three (3) minutes.

10. RECEIVED WRITTEN COMMUNICATIONS:

11. LATE RECEIVED WRITTEN COMMUNICATIONS:

12. FUTURE AGENDA ITEMS: Deferred Infrastructure Program (as needed), Lopez Water Contract Amendments (Late 2021), Wastewater CIP (Future year), Old Firehouse Art (June 2021), California Voting Rights Act (Mid to late 2021), District Flag Policy/ Pride Month (As directed), Social Media Policy/ Live Stream Board Meetings (As directed), Bill insert/ mailing policy (As directed), Letter to IWMA regarding Special District Representative/Alternate with a letter to SLO County regarding pulling out of the IWMA (May/ June 2021), OCSD Policy & Procedure Manual review (As directed), CSDA Transparency Certification (As directed)

13. FUTURE HEARING ITEMS:

14. CLOSED SESSION:

15. ADJOURNMENT:

This agenda was prepared and posted pursuant to Government Code Section 54954.2. Agenda is posted at the Oceano Community Services District, 1655 Front Street, Oceano, CA. Agenda and reports can be accessed and downloaded from the Oceano Community Services District website at www.oceanocsd.org

ASSISTANCE FOR THE DISABLED If you are disabled in any way and need accommodation to participate in the Board meeting, please call the Clerk of the Board at (805) 481-6730 for assistance at least three (3) working days prior to the meeting so necessary arrangements can be made.

PAGE INTENTIONALLY LEFT BLANK

AMENDED 5/18/2021

Pursuant to Governor Newsom's Executive Order N-29-20, members of the Board of Directors and staff will participate in this meeting via a teleconference. Members of the public can submit written comments to the Board Secretary at boardcomment@cambriacsd.org.



CAMBRIA COMMUNITY SERVICES DISTRICT

Thursday, May 20, 2021 - 2:00 PM

AGENDA

REGULAR MEETING OF THE CAMBRIA COMMUNITY SERVICES DISTRICT BOARD OF DIRECTORS

Please click the link below to join the webinar:

<https://zoom.us/j/95110314212?pwd=YjV0VkNpRWdwa095L1ZhWTlxdGZnZz09>

Passcode: 711817

Or iPhone one-tap:

US: +16699006833,,95110314212# or +12532158782,,95110314212#

Or Telephone:

Dial (for higher quality, dial a number based on your current location):

US: +1 669 900 6833 or +1 253 215 8782 or +1 346 248 7799 or +1 312 626 6799 or +1 929 205 6099 or +1 301 715 8592

Webinar ID: 951 1031 4212

International numbers available: <https://zoom.us/u/adpQijVl8m>

1. OPENING

- A. Call to Order
- B. Pledge of Allegiance
- C. Establishment of Quorum
- D. Report from Closed Session
- E. President's Report
- F. Agenda Review: Additions/Deletions

2. BOARD MEMBER COMMUNICATIONS

Any Board Member may make an announcement, report briefly on his or her activities, or ask a question for clarification.

3. PUBLIC SAFETY

- A. Sheriff's Department Report

B. CCSD Fire Chief's Report**4. PUBLIC COMMENT**

Members of the public may now address the Board on any item of interest within the jurisdiction of the Board but not on its agenda today. Future agenda items can be suggested at this time. In compliance with the Brown Act, the Board cannot discuss or act on items not on the agenda. Each speaker has up to three minutes.

5. CONSENT AGENDA

All matters on the consent calendar are to be approved by one motion. If Directors wish to discuss a consent item other than simple clarifying questions, a request for removal may be made. Such items are pulled for separate discussion and action after the consent calendar as a whole is acted upon.

- A.** Consideration to Adopt the April 2021 Expenditure Report
- B.** Consideration to Adopt the April 8, 2021 and April 15, 2021 Regular Meeting Minutes and April 13, 2021 and April 28, 2021 Special Meeting Minutes
- C.** Consideration to Adopt Resolution 14-2021 Regarding the Continued Local State of Emergency Declaration
- D.** Consideration to Direct Staff to Issue a Request For Proposal (RFP) for Zone 2 to 7 Transmission Main Santa Rosa Creek Pedestrian Bridge Project

6. REGULAR BUSINESS

- A.** Discussion and Consideration to Introduce Ordinance 01-2021 Amending Article IV of Title 3, Section 3.04.030 of the Cambria Community Services District Municipal Code Changing Reference to the Sustainable Water Facility (SWF) to the Water Reclamation Facility (WRF)
- B.** Discussion and Consideration Regarding the Parks, Recreation, and Open Space (PROS) Commission Project Recommendations for the Community Park Restroom Design
- C.** Discussion and Consideration of Third Quarter Budget Report for FY 2020/21 and Adoption of Resolution 15-2021 Amending the Fiscal Year 2020/21 Budget
- D.** Discussion and Consideration of Strategic Plan Status Report and Update
- E.** Discuss and Consider Urban Water Management Plan (UWMP) Demand Components and Proposed Water Shortage Stages of the 2020 Water Shortage Contingency Plan (WSCP) Added
Late

7. MANAGER REPORTS

- A.** Public Comment: The President will be asking for public comment before the reports.
- B.** General Manager's Report
- C.** Finance Manager's Report
- D.** Utilities Report

8. FUTURE AGENDA ITEM(S)

This is an opportunity to request a formal agenda report be prepared and the item placed on a future agenda. No formal action can be taken except to direct the General Manager to place a matter of business on a future agenda by majority vote.

9. ADJOURN